

# 46-220 Reconditioning steering gear

## A. Steering gear 765.7 (LS 90)

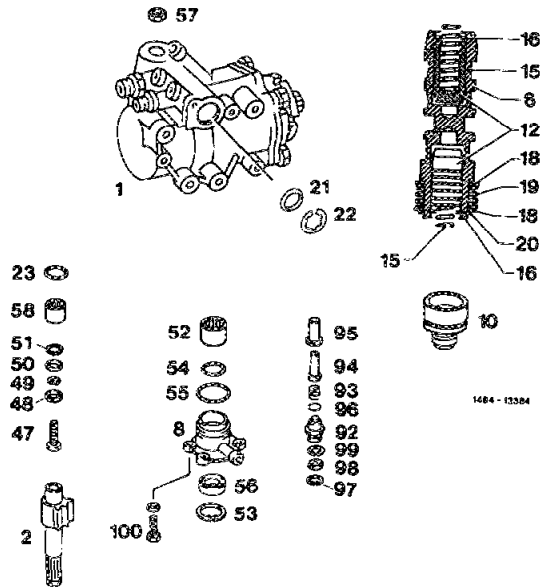

1 Steering case	Clamp with special tool 123 589 03 59 00
2 Pitman shaft	Check for wear on bearing points and on tooth segment, as well as for distortion. Attention! Pay attention to tothing.
6 Control valve	Pay attention to different versions, do not disassemble!
8 Steering case cover with needle sleeve	Check needle sleeve for damage and quiet running. If needle sleeve is damaged, renew case cover.
10 Closing cap	
12 Reaction bolt	Different diameters, according to steering gear model designation
15 Compression spring	
16 Locking ring	
18 Thrust washer	
19 Compression spring	
20 Locking ring	
21 O-ring (closing cap)	Renew
22 Locking ring	Renew
23 O-ring	Renew
47 Adjusting screw	Mount free of play
48 Thrust washer	
49 Locking ring	Renew
50 Thrust ring	
51 Locking ring	Renew
52 Needle sleeve	Check, renew case cover if required
53 Locking ring	Renew
54 O-ring	Renew
55 O-ring	Renew
56 Radial sealing ring	Renew, special tool 116 589 07 43 00

57	Self-locking hex. nut . . . . .	60-65 Nm
		Control valve 2nd version
58	Needle bearing . . . . .	Check for damage and quiet running
92	Cover	
93	Compression spring	
94	Spring bolt	
95	Bushing	
96	O-ring . . . . .	Renew
97	Locking ring . . . . .	Renew
98	Thrust ring	
99	Locking ring	
100	Hex. head screws . . . . .	Renew, 30-35 Nm

# 46-220 Reconditioning steering gear

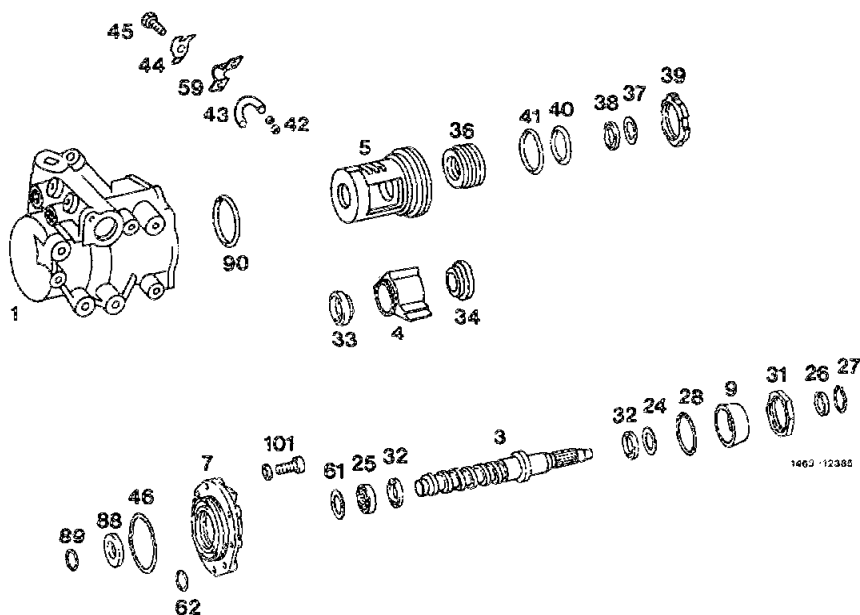

1 Steering case	Check needle sleeve at top in steering case for damage and quiet running. If required, remove needle sleeve with a conventional puller and renew. Special tool for mounting 123 589 03 59 00
3 Steering worm	Check ball circuit for score marks. Pay attention to different version, according to steering model designation.
4 Steering nut	Special tool for friction torque 116 589 03 21 00 or 123 589 02 21 00, 116 589 02 21 00 123 589 00 08 00 001 589 81 21 00
5 Working piston	Pay attention to toothing and version (with and without compensation for play) Special tool 201 589 02 59 00 123 589 02 59 00
7 Bearing cap	Pay attention to different version, according to steering model designation.
9 Bearing insert with needle sleeve	Check needle sleeve for damage and quiet running. Renew bearing insert completely, if required. Special tool 000 589 00 05 00, 116 589 08 43 00, 123 589 01 16 00, 123 589 02 07 00
24 Axial washer	
25 Needle sleeve	Renew
26 Radial sealing ring	Renew
27 Locking ring	Renew
28 O-ring	Renew
31 Slot nut or hex. nut	140-160 Nm Special tool 126 589 00 16 00, 123 589 01 07 00 or 123 589 09 09 00
32 Axial cyl. roller cage	Check for quiet running and damage
33 Axial angular ball bearing	Check for quiet running and damage
34 Axial cyl. roller cage	Check for quiet running and damage
36 Screw cover (hex.)	Special tool depending on version
36a Screw cover (square)	123 589 01 16 00, 123 589 05 09 00 123 589 07 09 00, 123 589 06 09 00

37	O-ring	Renew
38	Sealing ring (teflon)	Renew
39	Slot nut	200-240 Nm
39a	Hex. nut	Special tool 126 589 00 16 00 and 123 589 00 07 00 or 123 589 09 09 00
40	O-ring	Renew
41	Sealing ring (teflon)	Renew
42	Steel balls	24 each
43	Ball guide half	Check for damage
44	Fastening clamp	
45	Hex. head screw	12-16 Nm
46	O-ring	Renew
59	Locking plate	Renew
61	Axial washer	
62	O-ring	Renew
88	Sealing ring (teflon) in bearing cap	Renew
89	O-ring in bearing cap	Renew
90	Stop ring	Different thickness according to steering model designation
101	Hex. head screws	60-65 Nm

# 46-220 Reconditioning steering gear

## Special tools

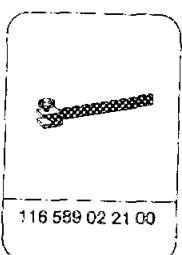
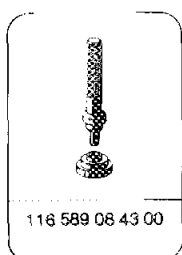
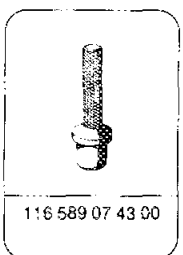
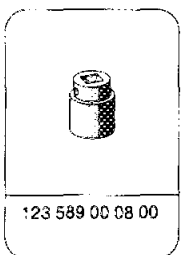
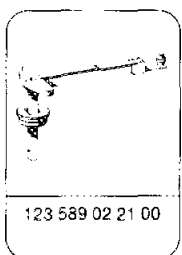
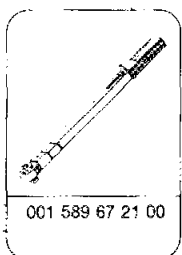
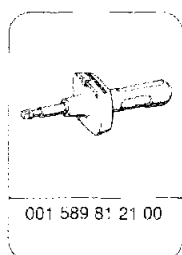
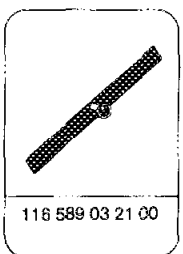
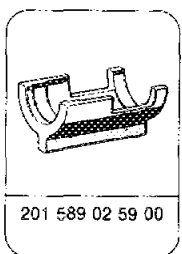
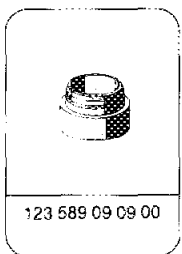
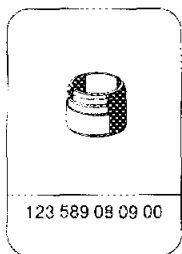
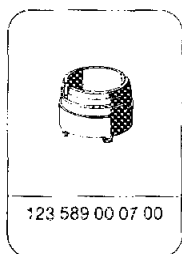
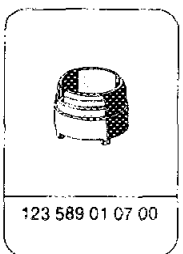
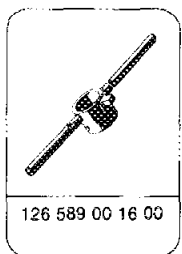
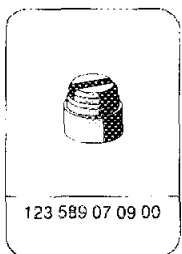
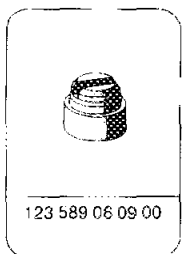
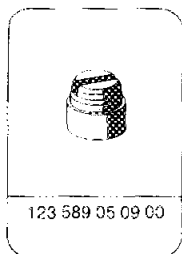
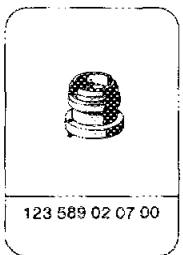
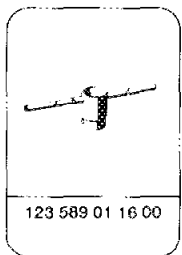
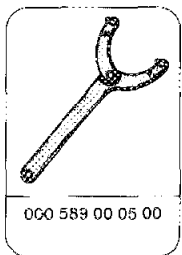
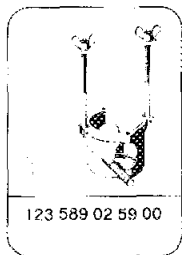
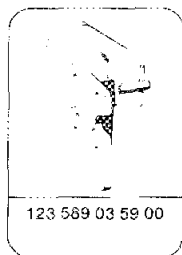

**Conventional tool**

Box wrench, plug-type 19 mm for  
torque wrench 001 589 67 21 00

e.g. made by Wille, D-5600 Wuppertal  
Order No. 732/40 - 19 mm

**Data**

Number of balls in ball circuit

24

**Adjusting values**

Ncm

Friction torque of steering worm in bearing cap  
prior to preloading bearing insert

$\leq 12$

Additional friction torque of steering worm after  
preloading bearing insert

4-7

Friction torque of steering nut in working piston

6-10

Friction torque of ball circuit steering worm - steering nut

30-50

Total friction torque

110-160

**Note**

The following description covers assembly and adjustment of the following steering gears:

Steering without and with inside stop

Steering with automatic compensation for play

The data valid for the individual models and steering gears with regard to pitch of ball circuit and diameters of reaction piston are shown in list "Differentiating characteristics of steering gears" 46-010.

# 46-220 Reconditioning steering gear

- 1st version  
 Power steering without inside stop  
 (steering 765.700, 765.701, 765.702, 765.703)
- 1 Steering case
  - 2 Pitman shaft
  - 3 Steering worm
  - 4 Steering nut
  - 5 Working piston
  - 7 Bearing cap
  - 9 Bearing insert
  - 36 Screw cap

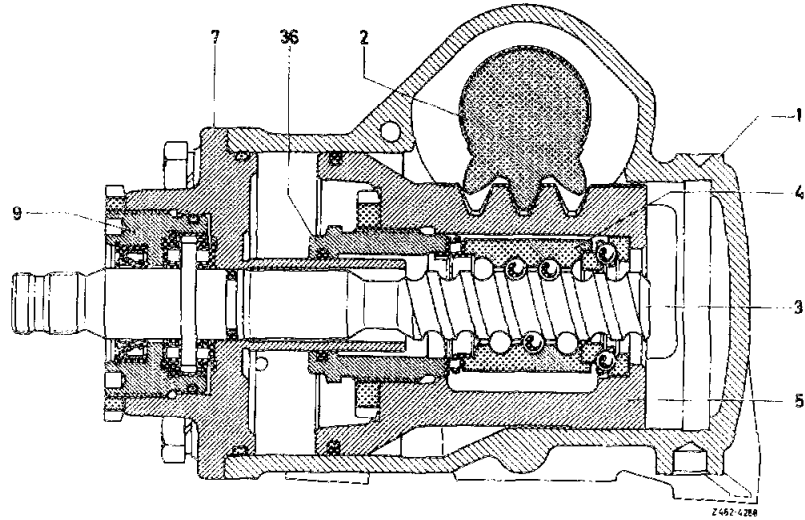

- 2nd version  
 Power steering with inside stop  
 (steering 765.704, 765.706)
- 1 Steering case
  - 2 Pitman shaft
  - 3 Steering worm
  - 4 Steering nut
  - 5 Working piston
  - 7 Bearing cap
  - 9 Bearing insert
  - 36 Screw cap
  - 90 Stop ring
  - A Stop for working piston

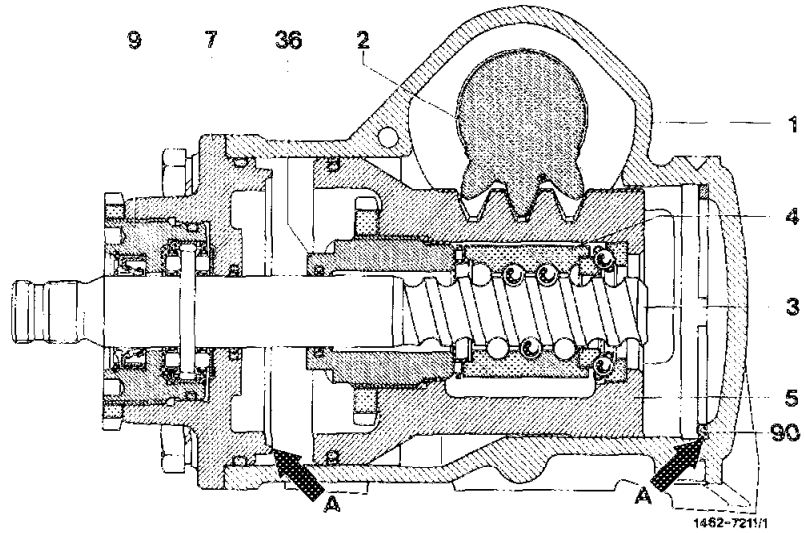

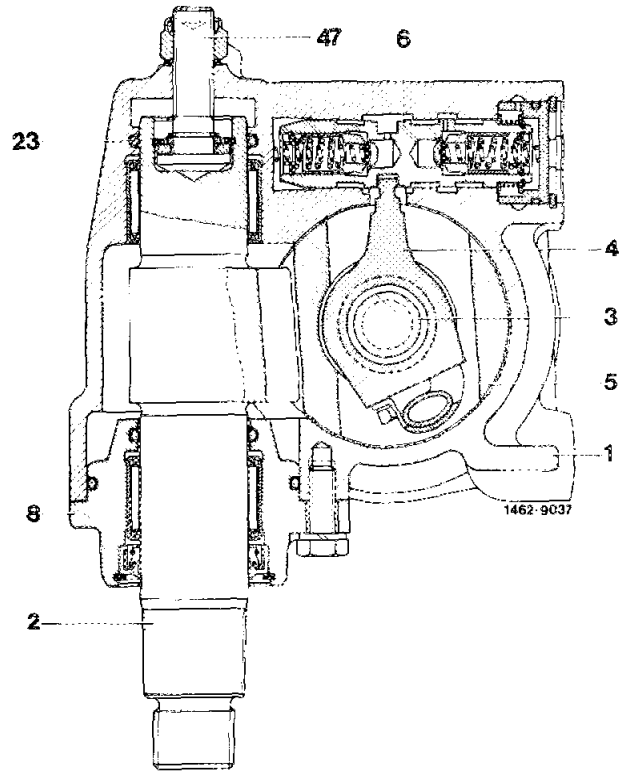

- Power steering without compensation for play  
(steering 765.700, 765.701, 765.702, 765.703, 765.704)
- 1 Steering case
  - 2 Pitman shaft
  - 3 Steering worm
  - 4 Steering nut
  - 5 Working piston
  - 6 Control valve
  - 8 Case cover
  - 23 O-ring
  - 47 Adjusting screw

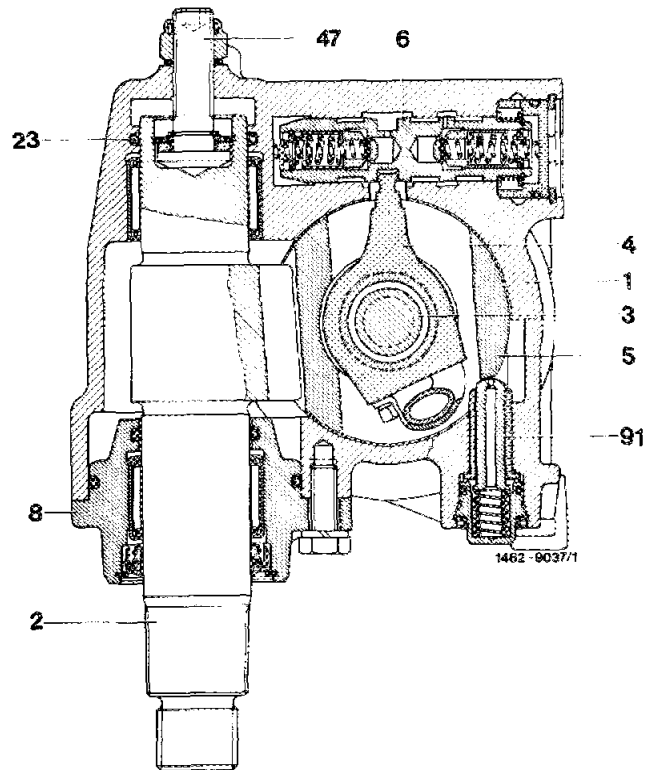

- 3rd version  
Power steering with automatic compensation for play  
(steering 765.706)
- 1 Steering case
  - 2 Pitman shaft
  - 3 Steering worm
  - 4 Steering nut
  - 5 Working piston
  - 6 Control valve
  - 8 Casing cap
  - 23 O-ring
  - 47 Adjusting screw
  - 91 Automatic compensation for play

## 46-220 Reconditioning steering gear

### Disassembly

1 Fasten steering (1) to assembly device (0102).

Special tool 123 589 03 59 00

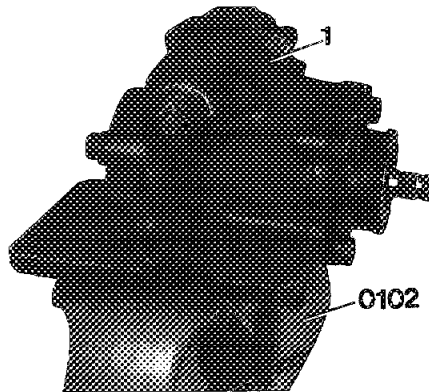

2 On steering 3rd version (with automatic compensation for play) turn steering worm until working piston is slightly in a lefthand or righthand turn.

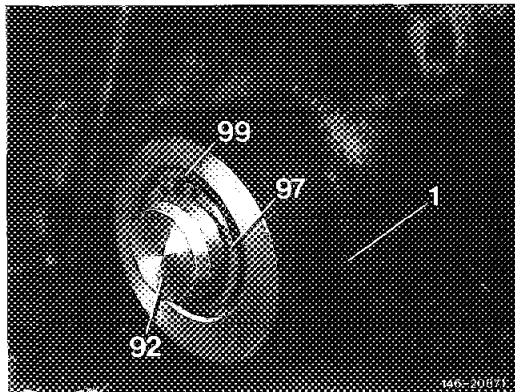

3 Remove locking ring (97) from cover (92), then remove thrust ring (98) from steering case.

Remove locking ring (99) from steering case (1).

Remove compression spring (93), spring bolt (94) and bushing (95).

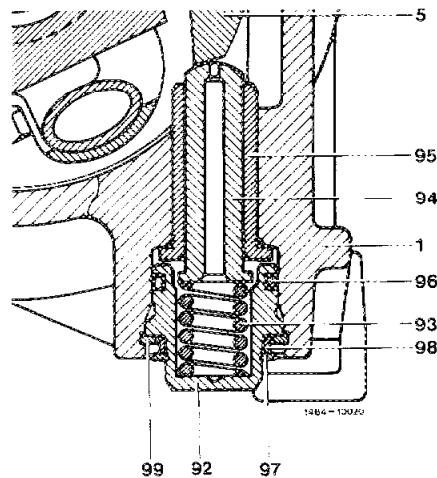

4 Unscrew hex. screws for fastening casing cover (8) to steering case (1).

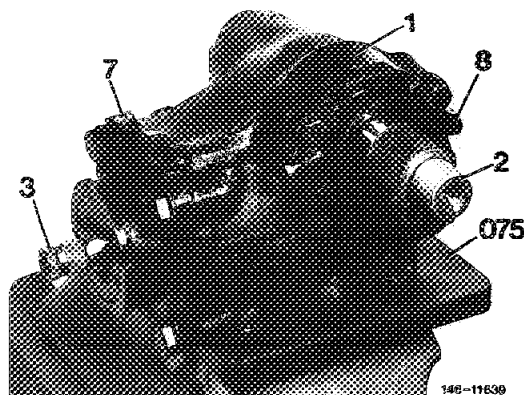

5 Unscrew self-locking hex. nut (57) from adjusting screw (47), while applying counterhold to adjusting screw.

6 In center position of steering, turn adjusting screw to the right, which will force pitman shaft including casing cover out of steering case.

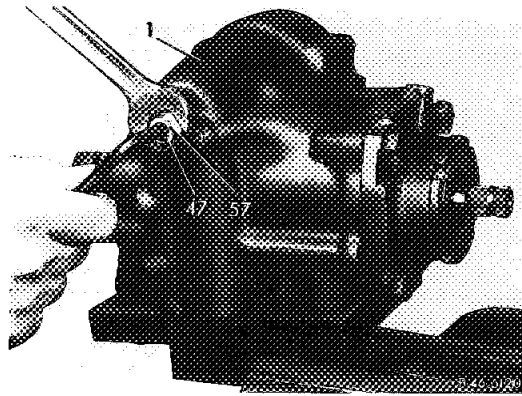

7 Remove casing cover (8) from pitman shaft (2).

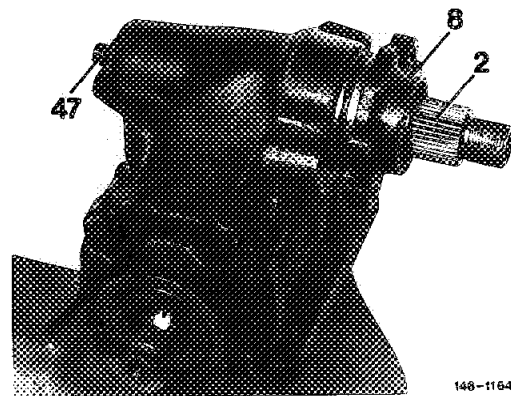

148-11647

8 Remove O-rings (54 and 55) from casing cover.

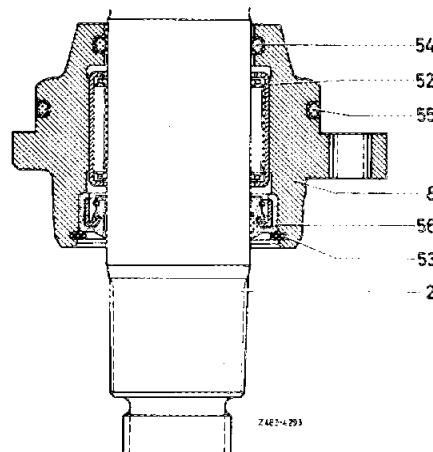

9 Remove locking ring (53) and radial sealing ring (56) from casing cover (8).

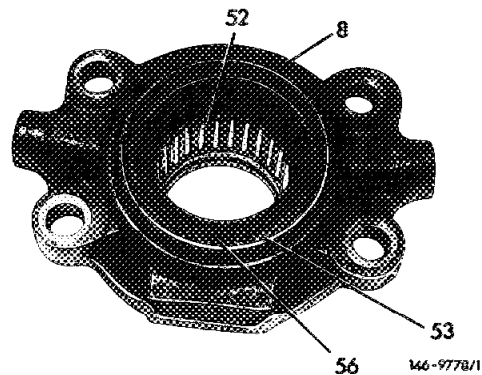

## 46-220 Reconditioning steering gear

10 Take locking ring (51) out of adjusting screw (47), then remove thrust ring (50).

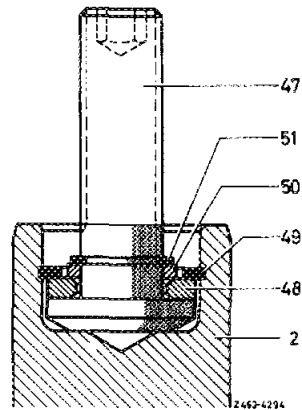

11 Remove locking ring (49) from pitman shaft (2). Remove adjusting screw (47) including thrust washer (48).

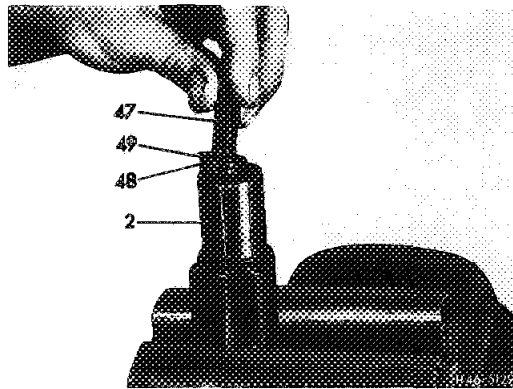

12 Unscrew hex. screws for fastening bearing cap (7) to steering case (1).

13 Slip steering coupling on steering worm, turn steering worm to the left until bearing cap is pushed slightly out of steering case.

### Attention!

Do not turn too far, since otherwise the balls may fall out of ball circuit.

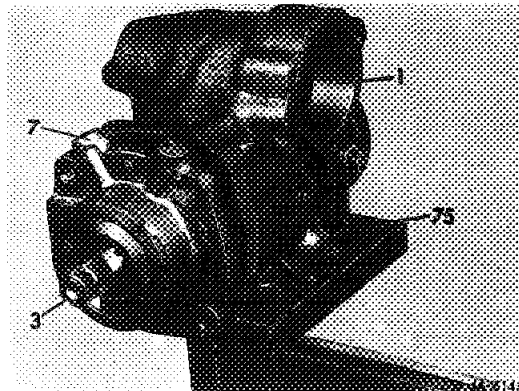

14 Remove bearing cap together with steering worm and working piston out of steering case.

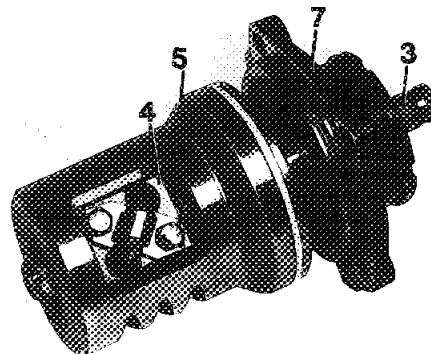

146-11635

15 Place measuring device on splining of steering worm and measure friction torque of ball circuit. The friction torque steering nut – steering worm should amount to 5–50 Ncm (i.e. 50 g in notch "10" as lowest or 500 g in notch "6" to "12" as highest friction torque).

Special tool 116 589 03 21 00

Note: If the friction torque is lower, the ball circuit has play; if it is higher, ball circuit is damaged. In both cases, replace the steering.

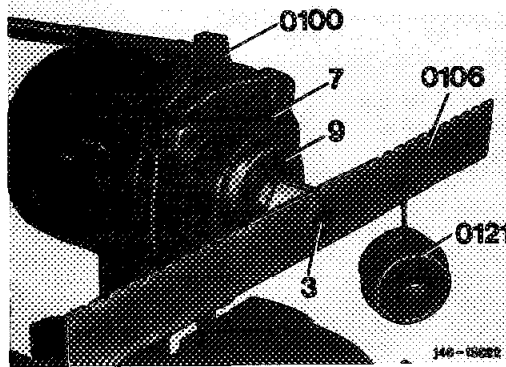

16 The friction torque can also be measured with torque wrench in combination with respective socket.

Special tool 123 589 02 21 00 and  
123 589 00 08 00

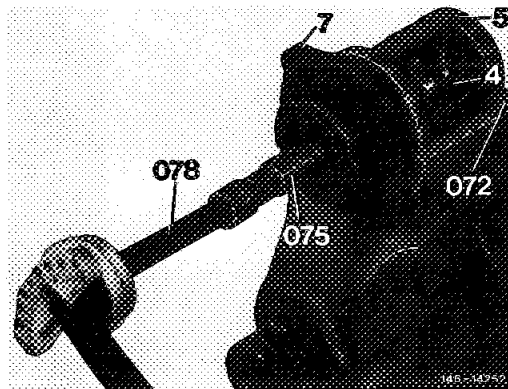

17 Screw steering worm (3) out of steering nut (4), making sure that no balls (42) are lost.

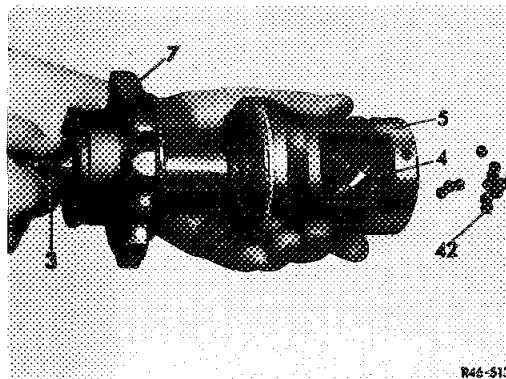

18 Remove O-ring from bearing cap (7) and fasten bearing cap in device (0100).

Special tool 123 589 02 59 00

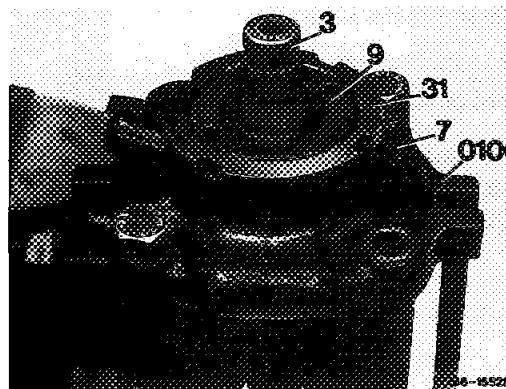

## 46-220 Reconditioning steering gear

19 Unscrew slot nut or hex. nut with tommy handle (0103) and unscrew pertinent insert (0104) from bearing insert.

Special tool 126 589 00 16 00 and  
123 589 01 07 00 or  
123 589 09 09 00

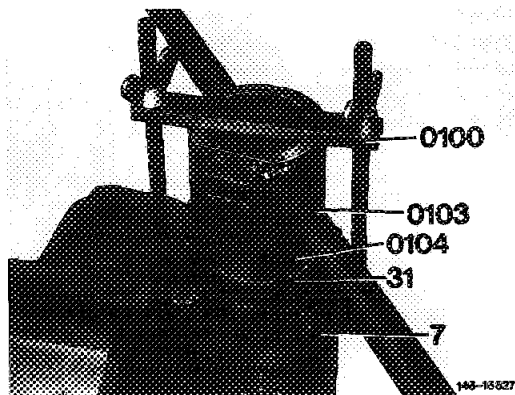

Layout bearing insert with slot nut

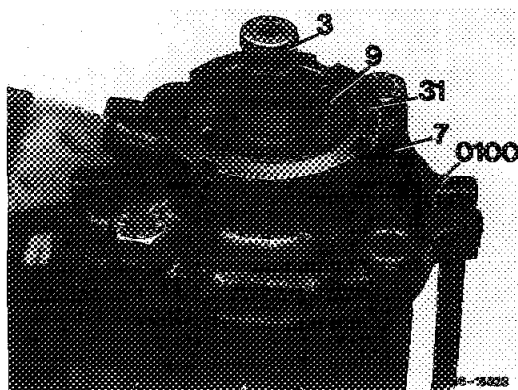

Layout bearing insert with hex. nut

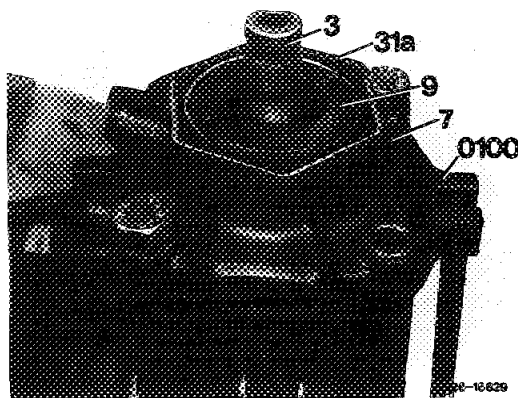

20 Unscrew bearing insert (9) with pin wrench from bearing cap (7).

Special tool: 000 589 00 05 00

Note: Bearing insert can also be unscrewed by means of the adjustable pin wrench.

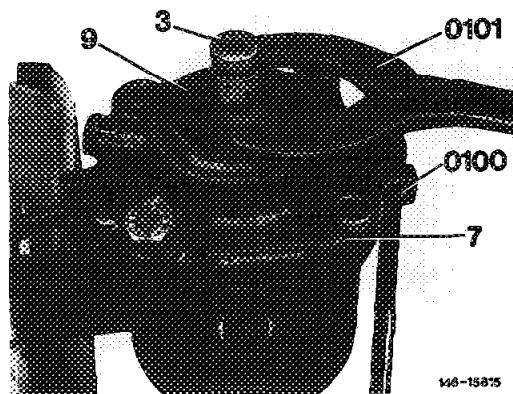

21 Remove steering worm (3) from bearing cap (7), remove axial cyl. roller cage (32) from steering worm

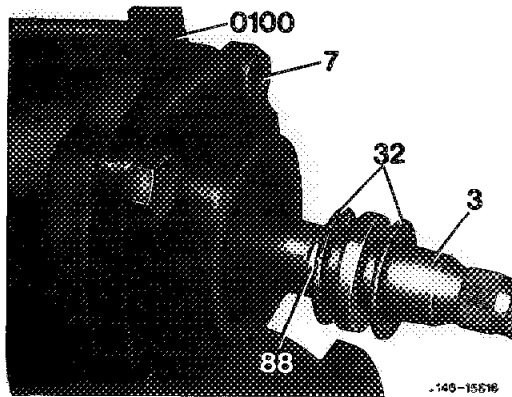

22 On 1st version, remove bearing cap/steering worm sealing ring (30) and O-ring (29) from steering worm (3).

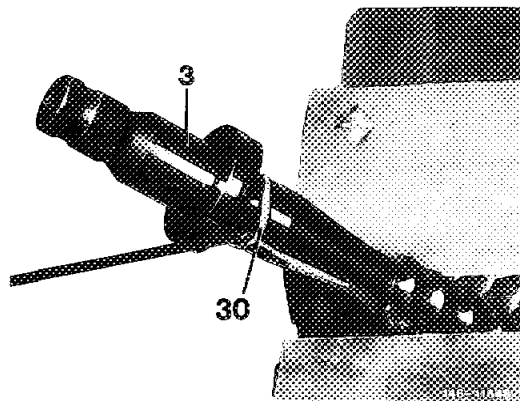

Bearing cap and steering worm  
1st version.  
Bearing cap with neck,  
sealing ring (teflon) and  
O-ring on steering worm

- 3 Steering worm
- 7 Bearing cap
- 9 Bearing insert
- 24 Axial washer
- 25 Needle sleeve
- 26 Radial sealing ring
- 27 Locking ring
- 28 O-ring
- 29 O-ring
- 30 Sealing ring (teflon)
- 31 Slot or hex. nut
- 32 Axial cyl. roller cage
- 46 O-ring
- 61 Axial washer

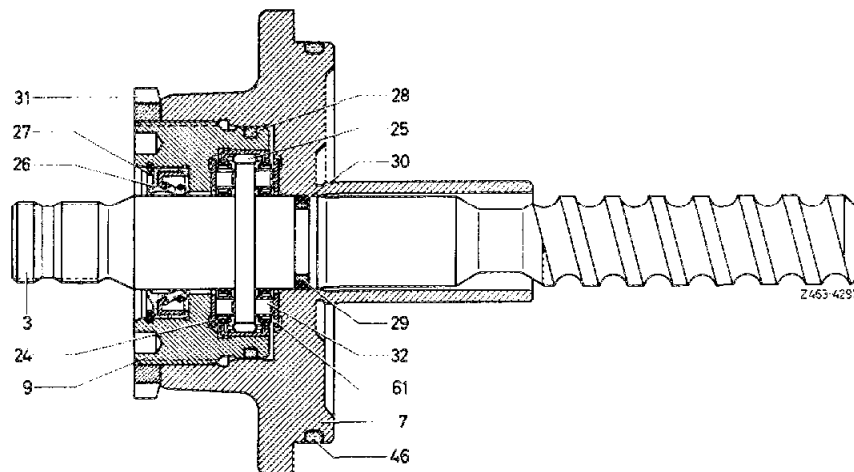

# 46-220 Reconditioning steering gear

Bearing cap and steering worm  
2nd version.  
Bearing cap without neck,  
sealing ring (teflon) and  
O-ring in bearing cap

- 3 Steering worm
- 7 Bearing cap
- 9 Bearing insert
- 24 Axial washer
- 25 Needle sleeve
- 26 Radial sealing ring
- 27 Locking ring
- 28 O-ring
- 31 Slot or hex. nut
- 32 Axial cyl. roller cage
- 45 O-ring
- 61 Axial washer
- 88 Sealing ring (teflon)
- 89 O-ring

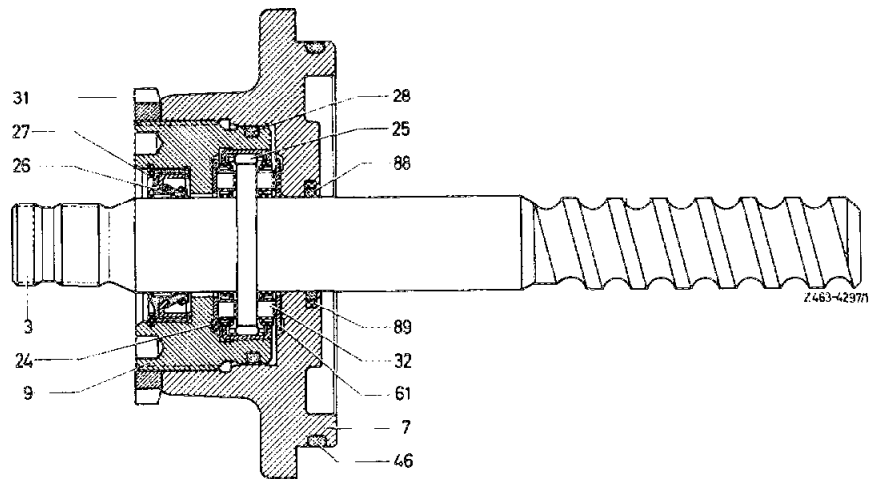

23 On 2nd version bearing cap/steering worm re-  
move sealing ring (89) and O-ring from bearing cap.

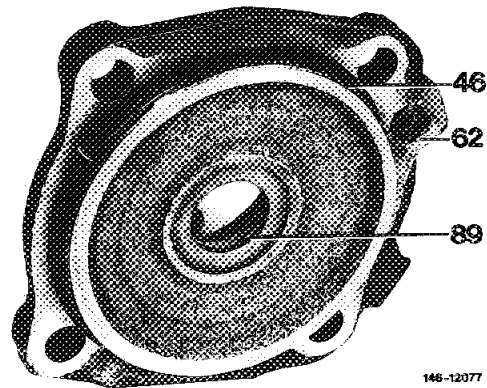

24 Remove axial washer (61) from bearing cap (7).

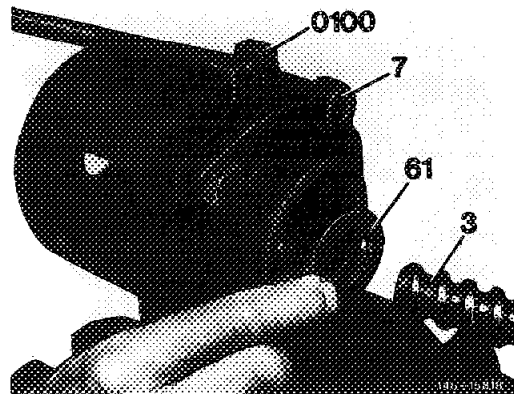

25 Unbend locking plate (59), unscrew hex. screws  
(45), remove locking plate, fastening clip (44) and  
both ball guide halves (43).

Special tool 201 589 02 59 00

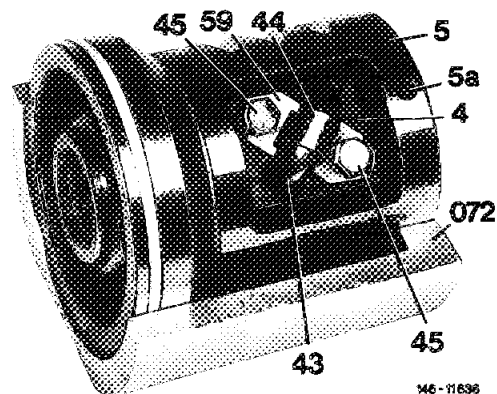

26 Clamp working piston (5) into device (0100) and secure with plug (0100 a).

Special tool 123 589 02 59 00

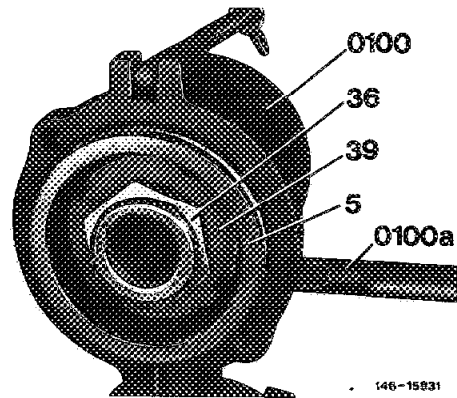

Layout screw cover (36) with hexagon width across flats 36 or 46 and slot nut (39)

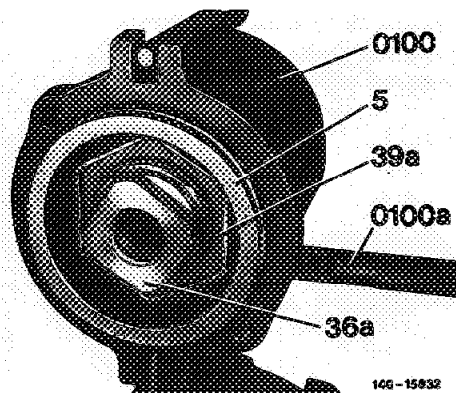

Layout screw cover (36 a) with square head and hex. nut (39 a)

27 Unscrew slot nut or hex. nut with pertinent insert (0104) including tommy handle (0103), then unscrew screw cover with pertinent insert.

Special tool for slot or hex. nut  
126 589 00 16 00, 123 589 00 07 00,  
123 589 09 09 00

Special tool for screw cover  
123 589 01 16 00, 123 589 05 09 00,  
123 589 06 09 00, 123 589 07 09 00

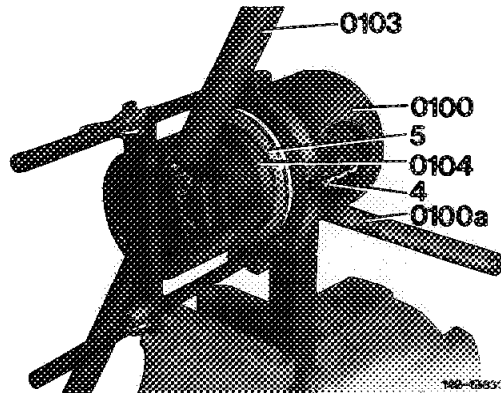

28 Take sealing ring (teflon) (38) and O-ring (37) from screw cover (36).

29 Remove axial cyl. roller cage (34) from steering nut (4) and steering nut from working piston (5).

30 Remove axial angular ball bearing (33) from working piston.

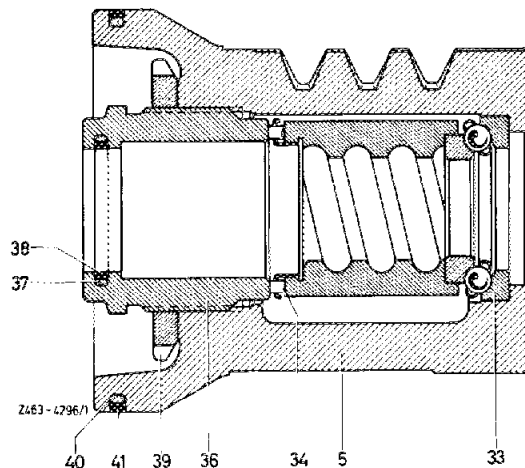

## 46-220 Reconditioning steering gear

31 Remove locking ring (22) and closing cover (10) from steering case.

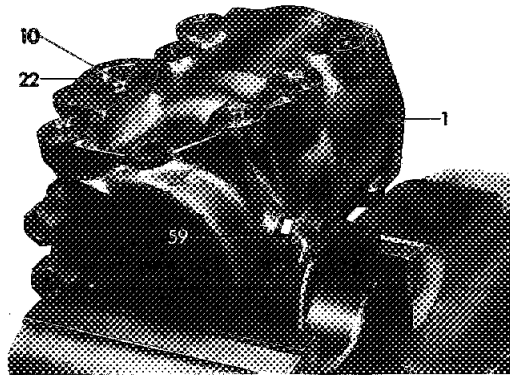

32 Remove control valve (6) from steering case (1), making sure that the springs on control valve 2nd, 3rd and 4th version are not falling out of reaction piston.

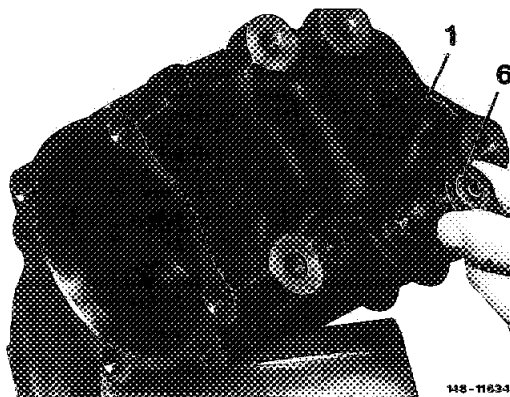

33 Remove O-ring (21) from closing cover.

a) Control valve 1st version

- 1 Steering case
- 6 Control valve
- 10 Closing cover
- 13 Supporting bolt
- 21 O-ring
- 22 Locking ring

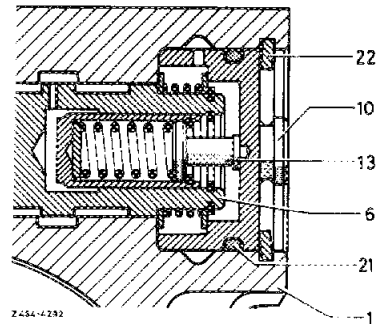

b) Control valve 2nd version

- 1 Steering case
- 6 Control valve
- 10 Closing cover
- 12 Reaction piston
- 21 O-ring
- 22 Locking ring
- 65 Spring bolt

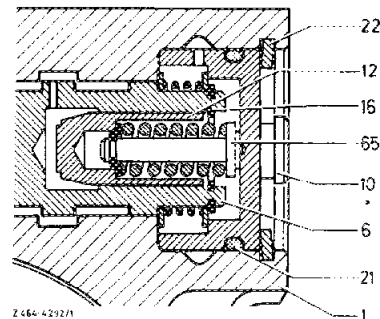

c) Control valve 3rd and 4th version

- 1 Steering case
- 6 Control valve
- 10 Closing cover
- 12 Reaction piston
- 16 Locking ring
- 21 O-ring
- 22 Locking ring
- 66 Compensating washer
- 67 Spring

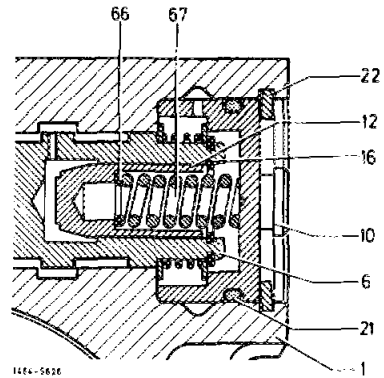

Checkup

Apply strict standards when checking steering components. When in doubt, replace respective part on principle.

Note

The ball circuit, that is, the steering worm and the steering nut, are assembled free of play at factory.

To maintain the specified clearance of 0.006 to 0.01 mm between straightedge of steering nut and control valve, both parts are assembled by selection.

The same applies to steering case and the control valve mounted inside case. For this reason, except for gasket and bearing set, only the pitman shaft, the working piston and the case cover are available as spare parts.

Steering worm

34 Check ball circuit on steering worm (3). If impact dents are showing up, replace steering.

Bearing insert

35 Check needle sleeve for wear. If needle sleeve is damaged, renew complete bearing insert (9).

- 3 Steering worm
- 7 Bearing cap
- 9 Bearing insert
- 28 O-ring
- 29 O-ring
- 30 Sealing ring (teflon)
- 31 Slot nut
- 32 Axial cyl. roller cage
- 61 Axial washer

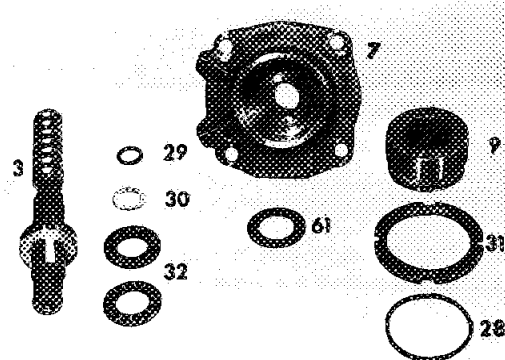

# 46-220 Reconditioning steering gear

## Working piston and steering nut

36 Remove sealing ring (41) and O-ring (40) from working piston (5). Press outer race of axial angular ball bearing (33) out of working piston.

37 Remove sealing ring (38) and O-ring (37) from screw cover (36).

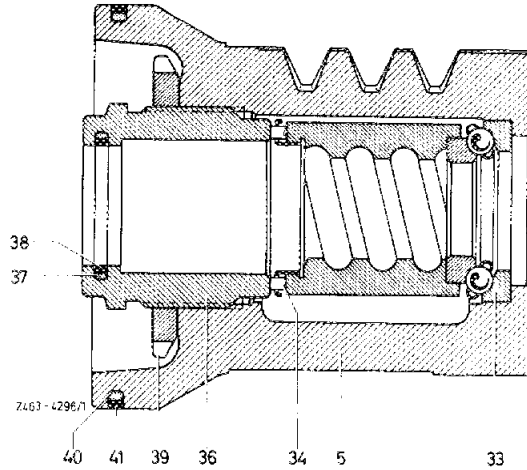

38 Check ball circuit in steering nut (4). If impact dents are showing up, replace steering.

- 4 Steering nut
- 4a Straightedge on steering nut
- 5 Working piston
- 33 Axial angular ball bearing
- 34 Axial cyl. roller cage
- 36 Screw cover
- 39 Slot or hex. nut
- 41 Sealing ring (taflon)

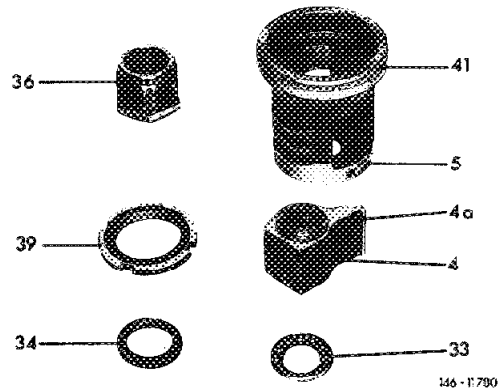

## Pitman shaft

39 Check pitman shaft (2) for wear at bearing points and on tooth segment, as well as for distortion or other damage. Renew pitman shaft, if required.

- 2 Pitman shaft
- 47 Adjusting screw
- 48 Thrust washer
- 49 Locking ring
- 50 Thrust ring
- 51 Locking ring

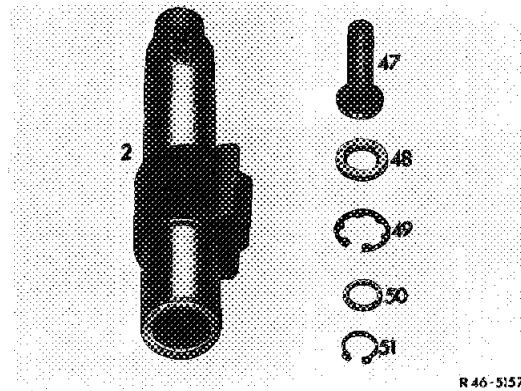

## Case cover

40 Check needle sleeve (52) for wear. If needle sleeve is damaged, renew complete case cover.

## Steering case

41 Check needle sleeve in steering case for wear. If required, pull out needle sleeve with a conventional puller.

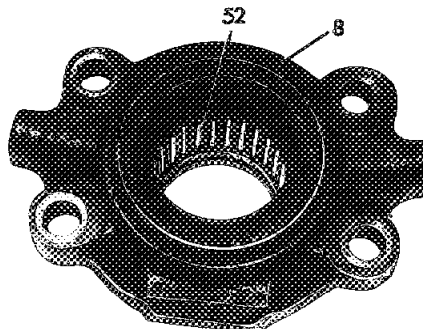

146-977B

**Control valve**

**Note:** On 1st version of control valve the reaction pistons have a diameter of 11 mm and the supporting pistons (13) are secured in reaction pistons by means of locking rings (14). On 2nd version (production starting middle of 1972) the diameter of the reaction pistons is 10 mm. Two spring bolts (65) are inserted in reaction pistons. On control valve 3rd version (production starting end of 1973) the reaction pistons have a diameter of 11 mm. Inside reaction pistons are compensating washer (66) and spring (67). Starting at the beginning of 1976 the control valve 4th version is installed, with a reaction piston diameter of 11.5 mm.

**1st version**

42 Check reaction piston (12) and supporting piston (13) in control valve (6) for easy operation. If required, remove and clean reaction piston after removing locking ring (16).

- 6 Control valve
- 12 Reaction piston (11 mm d.ia.)
- 13 Supporting piston
- 16 Locking ring
- 18 Thrust washer
- 19 Compression spring
- 20 Locking ring

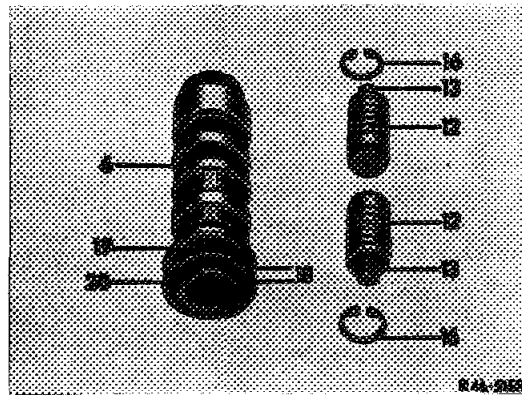

**Note:** Do not remove supporting bolts (13) from reaction pistons (12), since the spring load of compression spring (15) is adjusted by means of compensation washers (17).

- 6 Control valve
- 12 Reaction piston
- 13 Supporting piston
- 14 Locking ring
- 15 Compression spring
- 16 Locking ring
- 17 Compensating washer
- 18 Thrust washer
- 19 Compression spring
- 20 Locking ring

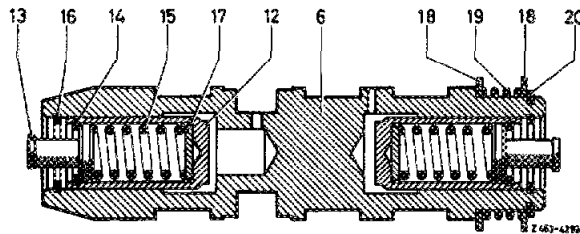

**2nd version**

43 Check reaction piston (12) in control valve (6) for easy operation.

- 6 Control valve
- 12 Reaction piston (10 mm dia.)
- 15 Compression spring
- 16 Locking ring
- 17 Compensating washer
- 18 Thrust washer
- 19 Compression spring
- 20 Locking ring
- 65 Spring bolt

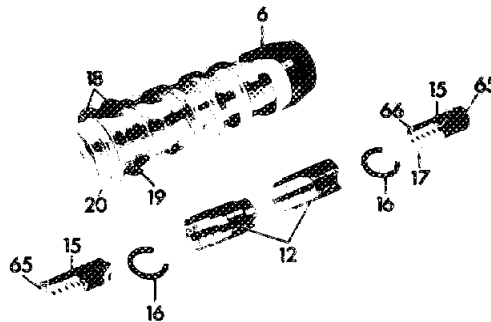

## 46-220 Reconditioning steering gear

**Note:** Do not disassemble spring bolts (65), since the spring preload is adjusted with compensating washers (17).

- 6 Control valve
- 12 Reaction piston (10 mm dia.)
- 15 Compression spring
- 16 Locking ring
- 17 Compensating washer
- 18 Thrust washer
- 19 Compression spring
- 20 Locking ring
- 65 Spring bolt

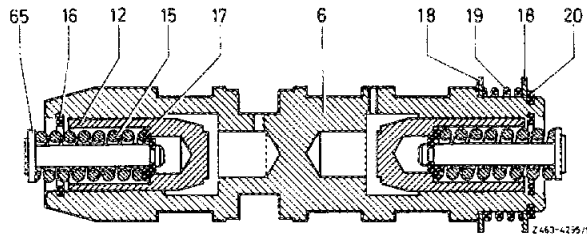

### 3rd and 4th version

44 Check reaction piston (12) in control valve (6) for easy operation.

**Note:** Do not mix up springs (15) and compensating washers (17) of both reaction pistons.

- 6 Control valve
- 12 Reaction piston (11 or 11.5 mm dia.)
- 15 Compression spring
- 18 Locking ring
- 17 Compensating washer
- 18 Thrust washer
- 19 Compression spring
- 20 Locking ring

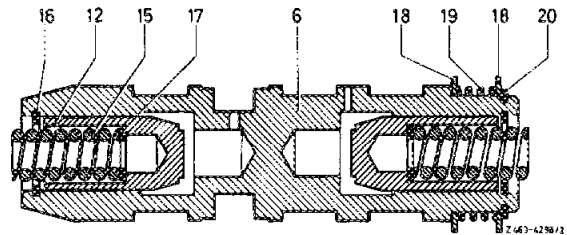

### Steering worm for steering without inside stop

45 Place lower axial cyl. roller cage (32) on steering worm (3).

46 Slip assembly sleeve (84) on steering worm (3) and mount O-ring (29) first, then sealing ring (30).

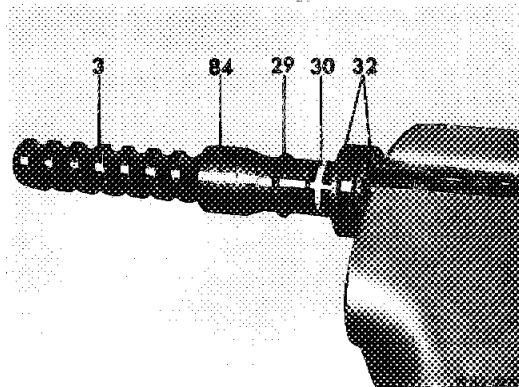

### Bearing cap for steering without inside stop

47 Fasten bearing cap (7) in device (0100), insert axial washer (61) into bearing cap, then steering worm (3).

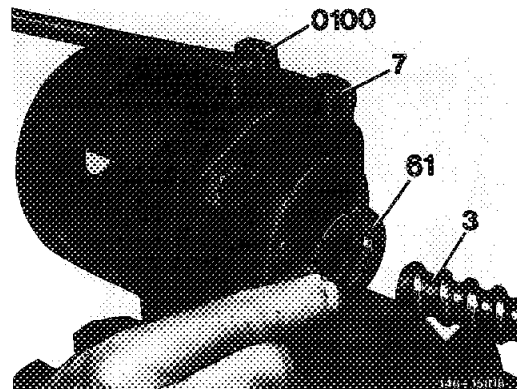

Bearing cap and steering worm for steering without inside stop:

Bearing cap with neck, sealing ring (teflon) and O-ring on steering worm

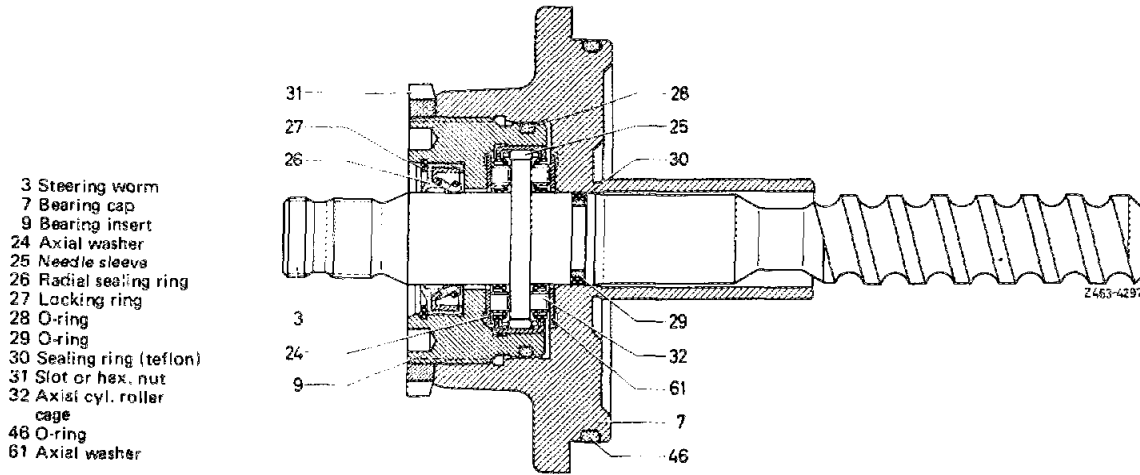

Bearing cap and steering worm for steering with inside stop:

Bearing cap without neck, sealing ring (teflon) and O-ring in bearing cap

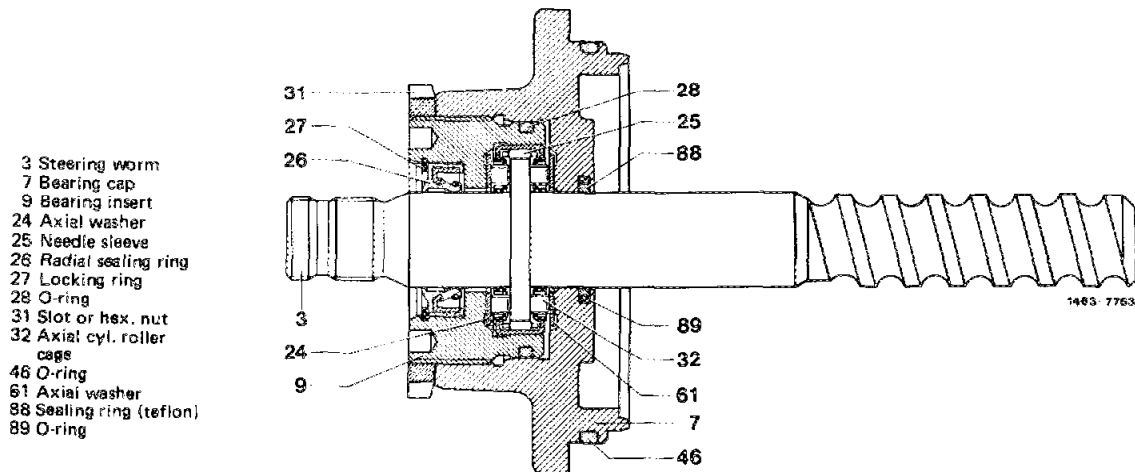

# 46-220 Reconditioning steering gear

## Steering worm for steering with inside stop

48 Place lower axial cyl. roller cage (32) on steering worm.

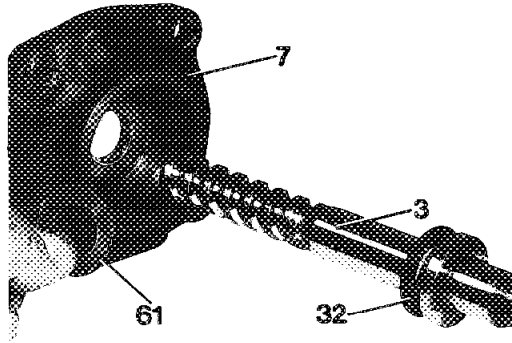

146-12078

## Bearing cap for steering with inside stop

49 Insert O-ring (89) and sealing ring into bearing cap.

50 Fasten bearing cap in device, insert axial washer in bearing cap, then steering worm, making sure that sealing ring is not damaged in bearing cap.

Special tool 123 589 02 59 00

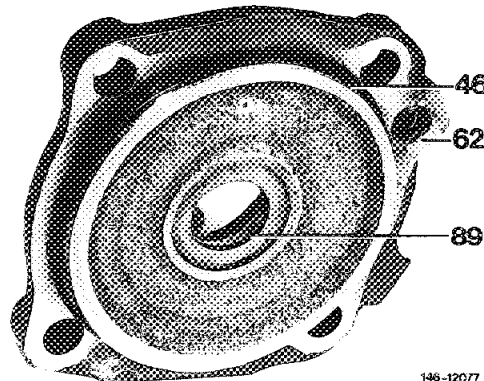

146-12077

### Attention!

Bearing caps for steering with and without inside stop are different in design.

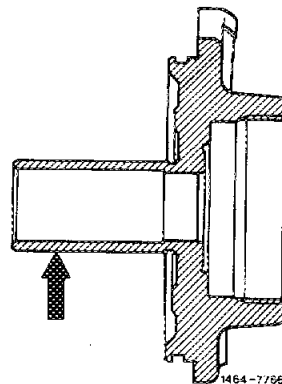

Bearing cap with neck (refer to arrow) for steering without inside stop  
Steering 765.700, 765.701, 765.702, 765.703

1464-7766

Only bearing cap with collar may be installed into steering with inside or additional stop. The collar is end stop for working piston at righthand lock.

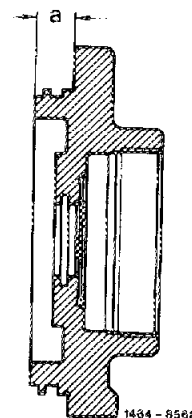

Bearing cap without neck for steering with additional stop  
Steering 765.701  
Dimension "a" = 11.4 ± 0.1 or 8.5 ± 0.1 (intermediate version)

1464-8568

Install only bearing cap with dimension "a" = 11.4 mm into steering with additional stop (code letter "S" on steering case).

Bearing cap without neck  
for steering with inside stop  
Steering 765.704  
Dimension „a“ =  $13.7 \pm 0.1$   
Steering 765.706  
Dimension „a“ =  $13 \pm 0.1$   
Steering 765.707  
Dimension „a“ =  $14.4 \pm 0.1$

51 Place upper axial cyl. roller cage (32) on steering worm.

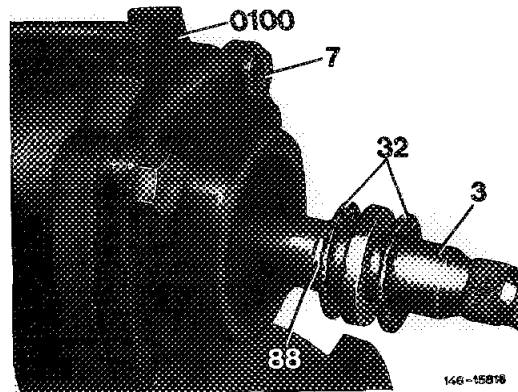

52 Press radial sealing ring into bearing insert (9) by means of pressing-in tool (73), fill space between both sealing lips with grease and insert locking ring.

Special tool 116 589 08 43 00

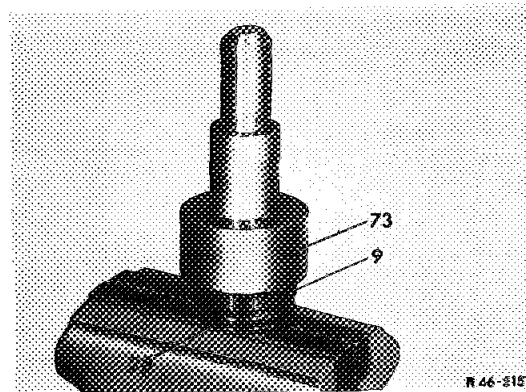

**Bearing cap and steering worm**

53 Screw bearing insert (9) into bearing cap (7) and tighten slightly. Screw slot nut or hex. nut on bearing insert.

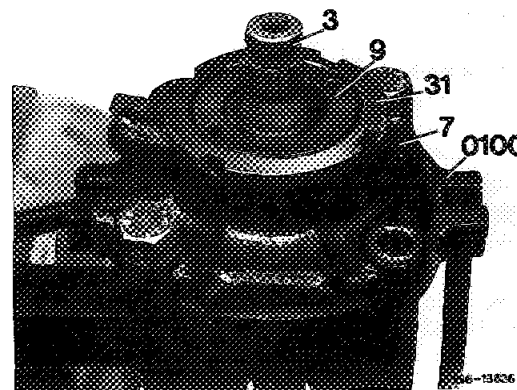

Layout bearing insert with slot nut

Layout bearing insert with hex. nut

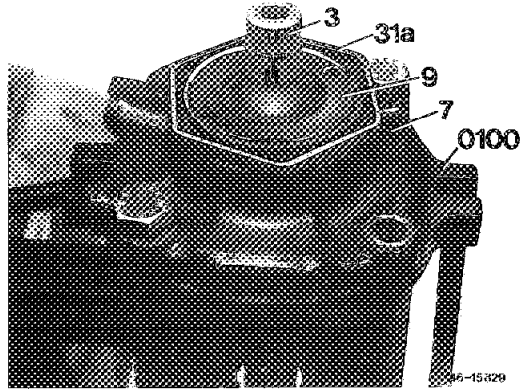

54 Measure friction torque of steering worm in bearing cap (sealing components only), for this purpose place measuring device (0106) on splining of steering worm. Friction torque should amount to  $\leq 12 \text{ Ncm} = 200 \text{ g}$  in notch "6" of measuring device.

Special tool 116 589 03 21 00

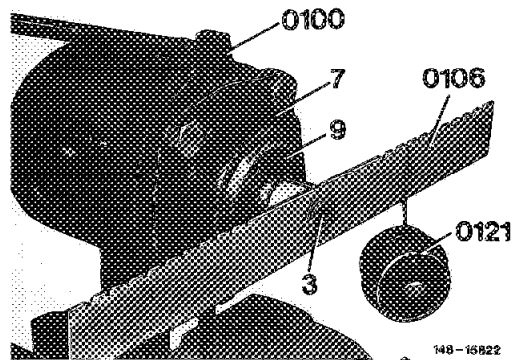

55 In combination with socket (0105) the friction torque can also be measured with torque screwdriver (0110).

Special tool 123 589 00 98 00,  
001 589 81 21 00

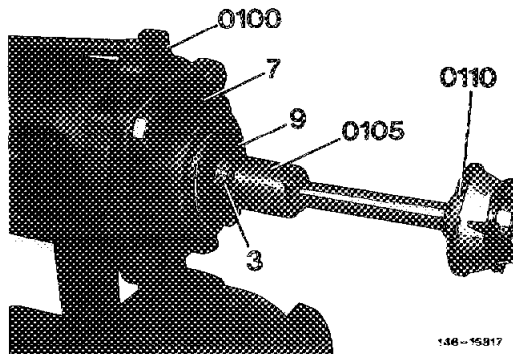

56 Tighten bearing insert (9) with insert including tommy handle (0107) until an additional friction torque of 4-7 Ncm is available. Tighten slot nut or hex. nut to 140-160 Nm and check friction torque once again.

Special tool for slot or hex. nut  
126 589 00 16 00, 123 589 01 07 00,  
001 589 67 21 00, 123 589 09 09 00

Special tool for bearing insert  
123 589 01 16 00, 123 589 02 07 00

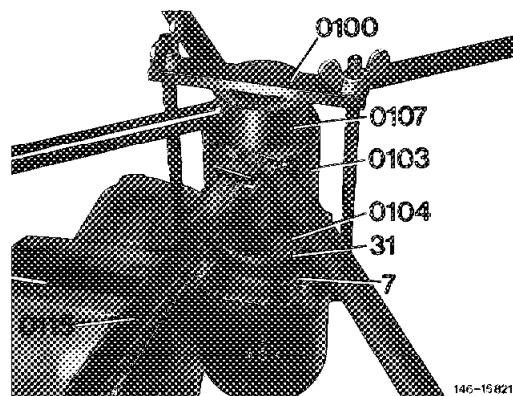

57 Remove bearing cap from device, mount both O-rings (46 and 62).

Bearing cap (with neck) and steering worm  
1st version for steering without inside stop  
sealing ring (teflon) and O-ring on steering  
worm

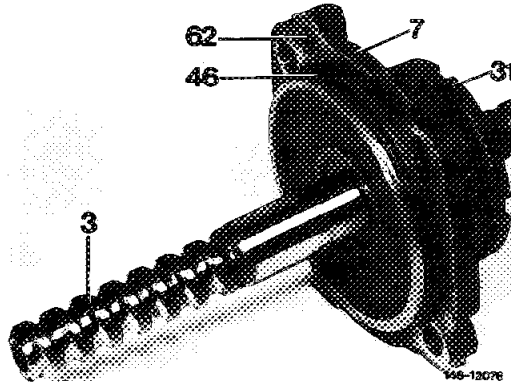
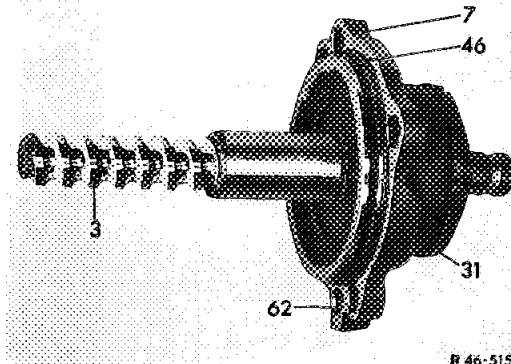

Bearing cap (without neck) and steering worm  
2nd version for steering with inside stop seal-  
ing ring (teflon) and O-ring in bearing cap

**Working piston and steering nut**

**Attention!**

The working pistons for steering with and without automatic compensation for play are different. The working piston with automatic compensation for play is provided with a recess (refer to arrow).

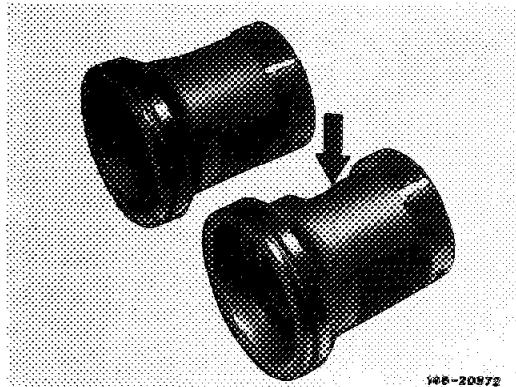

When renewing pitman arm pay attention to different version. Since the middle of 1983, working pistons and pitman shafts with modified tooth-  
ing are installed (2nd version with stamped notch,  
refer to arrow).

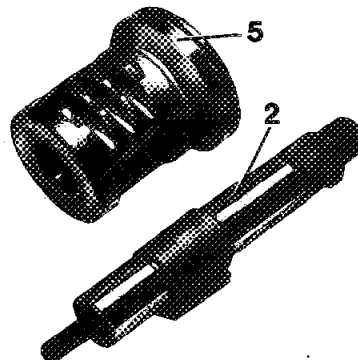

1st version

146-25965

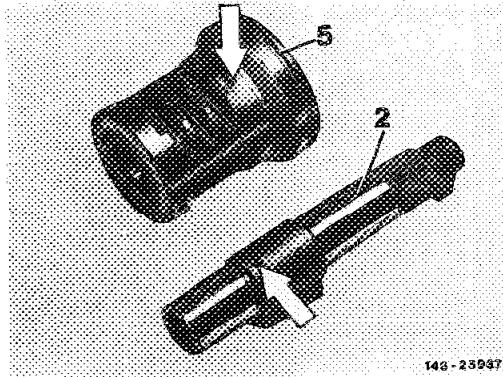

2nd version

58 Press outer race of axial angular ball bearing (33) into working piston (5), mount ball race.

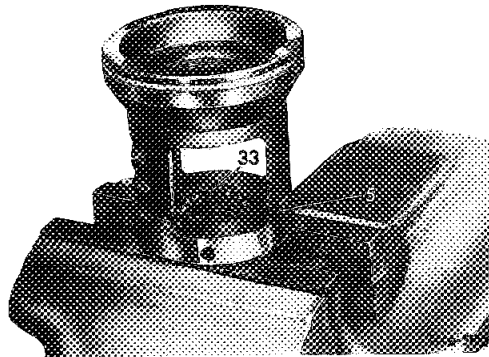

59 Insert steering nut (4) into working piston.

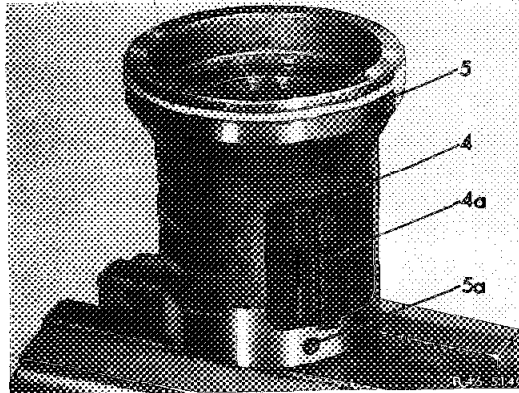

60 Insert axial cyl. roller cage (34) into working piston (5) in such a manner that the sheet metal guide on roller cage engages steering nut (4).

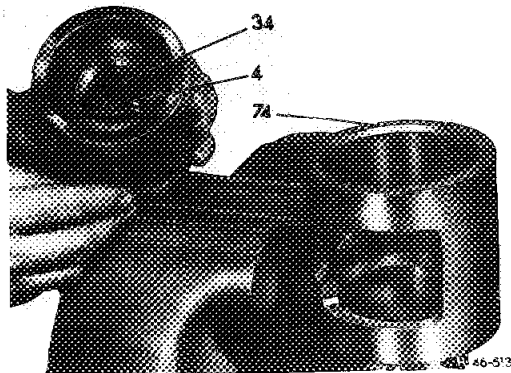

61 Insert O-ring (37) and sealing ring (38) into screw cap (36).

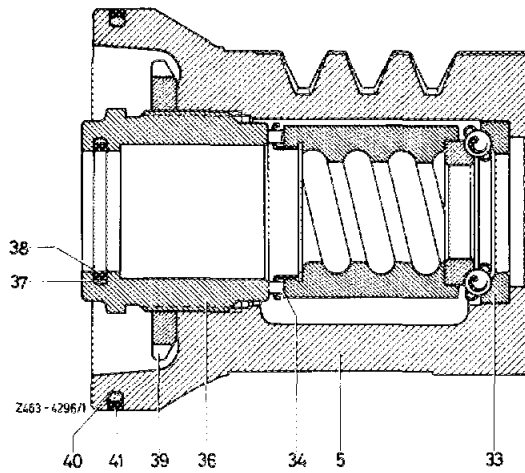

**Attention!**

The recessing depth in screw cap (power steering 1st version) for sealing ring and O-ring has been reduced. This screw cap is provided with notches (refer to arrow).

The sealing components for both screw cap versions are contained in repair set part No. 107 586 02 46. Pay attention to note in repair set.

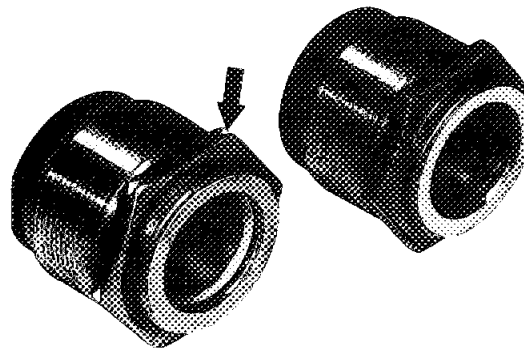

146-9658

62 Fasten working piston (5) including steering nut in device (0100) by means of plug (0100 a).

Special tool 123 589 02 59 00

63 Screw slot nut or hex. nut (39) on screw cap, screw cover (36) into working piston (5) and tighten slightly.

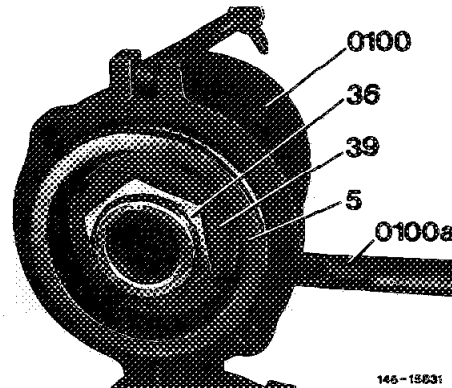

146-15631

Layout screw cap (36) with hexagon width across flats 36 or 46 mm and slot nut (39)

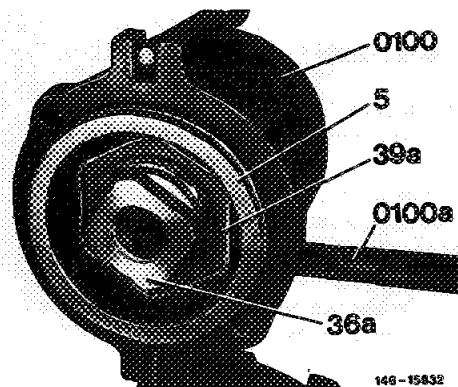

146-15632

Layout screw cap (36a) with square nut and hex. nut (39 a)

## 46-220 Reconditioning steering gear

64 For measuring friction torque of steering nut (4) in working piston (5), slip measuring device (0111) on straightedge of steering nut.

Special tool 116 589 02 21 00

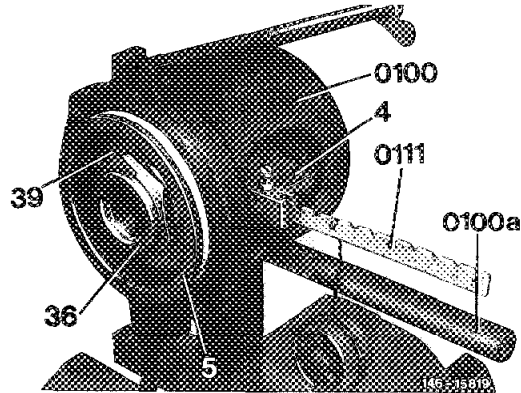

65 The friction torque should amount to 6–10 Ncm = 100 g in notch "6" up to "10" of measuring device. For adjusting screw cover, tighten with respective insert (0109) and tommy handle (0108) until weight on measuring device is just turning steering nut.

Special tool 123 589 01 16 00, 123 589 05 09 00, 123 589 06 09 00, 123 589 07 09 00

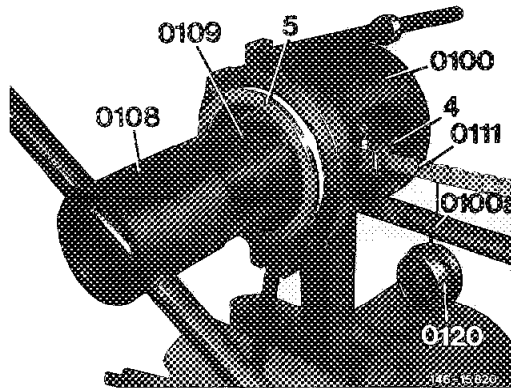

66 Secure screw cover with slot nut or hex. nut while applying counterhold to screw cover. Tightening torque 200–240 Nm. Then check friction torque of steering nut once again.

Special tool for slot or hex. nut  
126 589 00 16 00, 123 589 00 07 00,  
123 589 09 09 00

Special tool for screw cover  
123 589 01 16 00, 123 589 05 09 00,  
123 589 06 09 00, 123 589 07 09 00

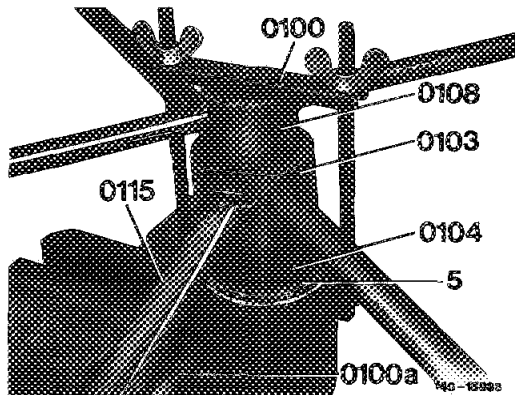

67 Unclamp working piston from device and place into assembly shell (72).

Special tool 201 589 02 59 00

### Steering worm, steering nut

68 Introduce steering worm (3) into steering nut until one ball circuit is fully visible through bore (for balls) in steering nut.

69 Introduce 17 balls into ball circuit while slowly turning steering worm to the right.

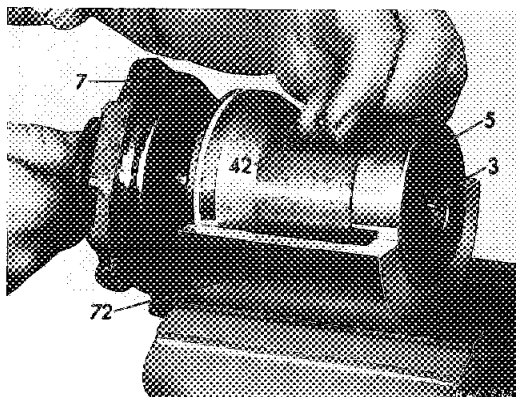

70 Fill one ball guide half (43) with grease and place the remaining 7 balls (42) into this guide half, close both openings with grease.

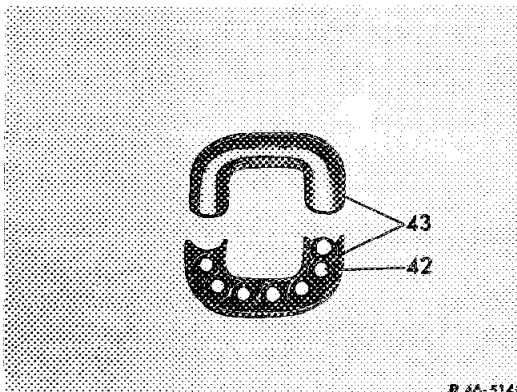

71 Insert ball guide halves (43) into steering nut.

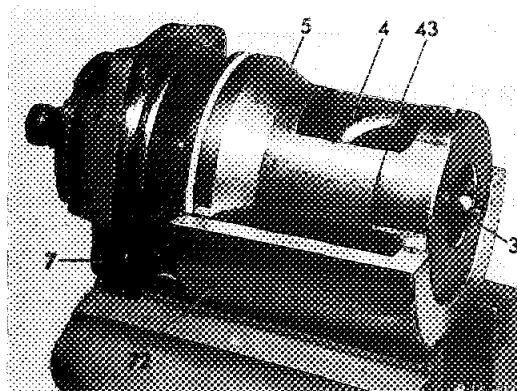

72 Place fastening shell with locking plate on steering nut (4). Screw in hex. screws and tighten to 12-16 Nm. Secure hex. screws.

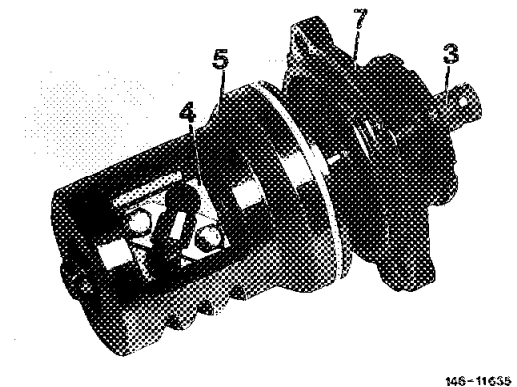

73 Place measuring device (70) on splining of steering worm (3) and measure friction torque of ball circuit.

Special tool 116 589 03 21 00

The friction torque steering nut – steering worm should be 5–50 Ncm, i.e. 50 g in notch "10" as lowest or 500 g in notch "6" to "12" as highest friction torque.

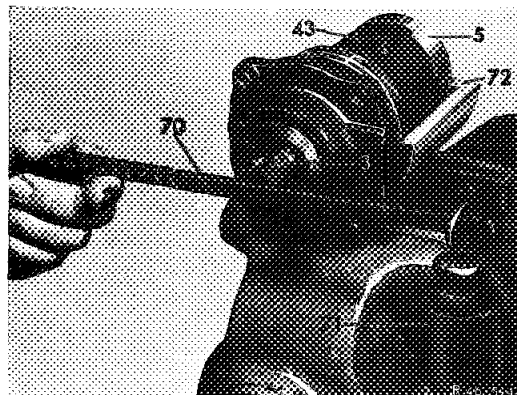

74 The friction torque can also be measured with torque wrench in combination with socket (075).

Special tool 123 589 02 21 00,  
123 589 00 08 00

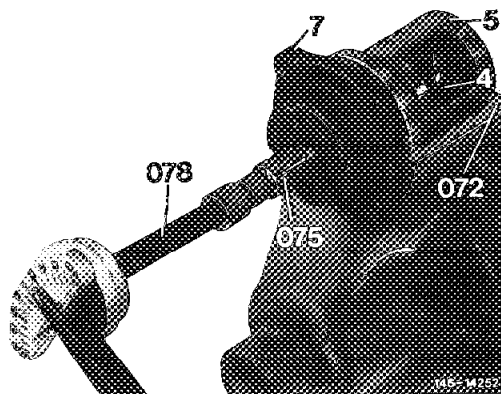

## Steering case, control valve

**Note:** On steerings with inside stop observe the following:

a) The steering case should be reinforced. Identification: one or two cast-in "y" (arrow).

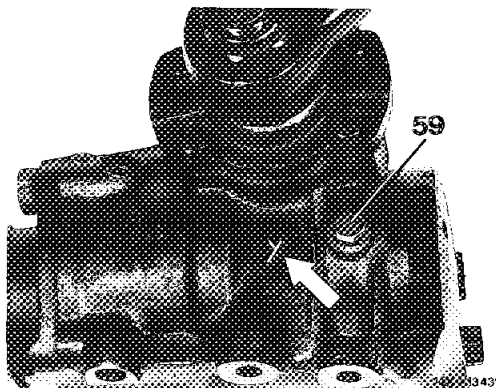

b) Stop ring (90) is located in steering case as a stop for working piston in lefthand lock. If the stop ring has been removed, note that there are rings of different thickness:

Steering 765.704 = 2.46-0.1

Steering 765.706 = 1.8-0.1

Steering 765.707 = 3.1-0.1

c) Steering 765.701 code letter "S" has no stop ring.



75 Renew O-ring (23) in steering case.

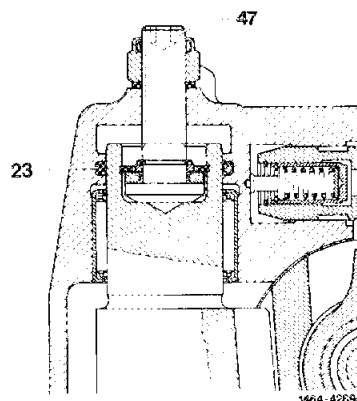

76 Insert control valve (6) into steering case.

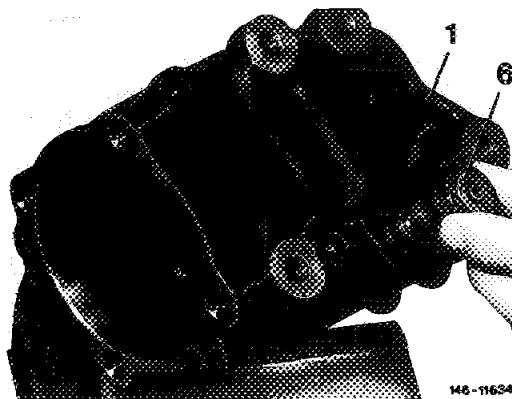

a) Control valve 1st version  
(reaction piston 1 mm dia.)

- 1 Steering case
- 6 Control valve
- 10 Closing cap
- 13 Supporting bolt
- 21 O-ring
- 22 Locking ring

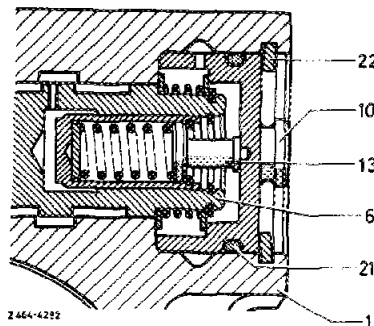

b) Control valve 2nd version  
(reaction piston 10 mm dia.)

Note: Grease spring bolts (65) so that they will not fall out when installing control valve.

- 1 Steering case
- 6 Control valve
- 10 Closing cap
- 12 Reaction piston
- 21 O-ring
- 22 Locking ring
- 65 Spring bolt

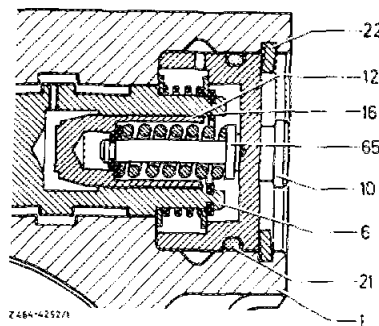

c) Control valve 3rd and 4th version  
(reaction piston 11 or 11.5 mm dia.)

Note: Grease springs (67) so that they will not fall out when installing control valve.

- 1 Steering case
- 6 Control valve
- 10 Closing cap
- 12 Reaction piston
- 16 Locking ring
- 21 O-ring
- 22 Locking ring
- 66 Compensating washer
- 67 Spring

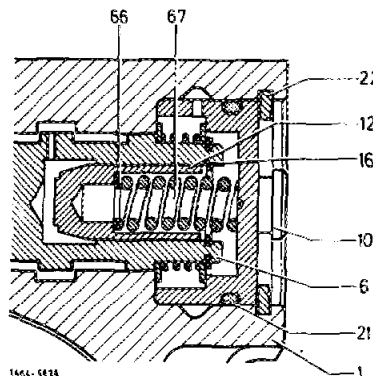

## 46-220 Reconditioning steering gear

---

77 Renew O-ring (21) on closing cap (10), then knock closing cap into steering case by means of a plastic hammer. Note that bore in cap faces upwards (to tapped hole in steering case for adjusting screw).

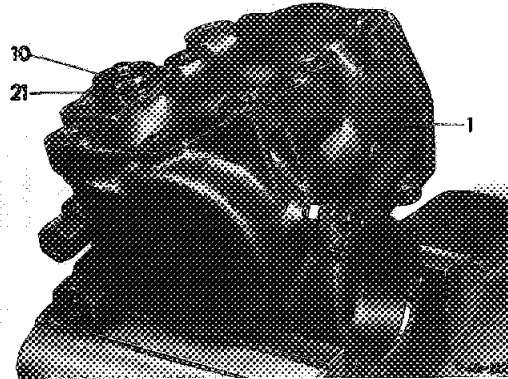

**Note:** The punched in code number in closing cap indicates the diameter of the reaction pistons (11 or 11.5 mm). For this reason, the cap should be identified with code number "1".

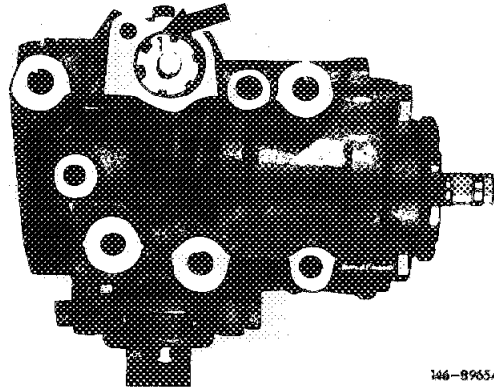

146-B965/1

78 Insert locking ring (22) into steering case (1) in such a manner that the lugs of the ring exert pressure on closing cover (10). Knock in locking ring by means of a mandrel until it is correctly seated in groove of steering case.

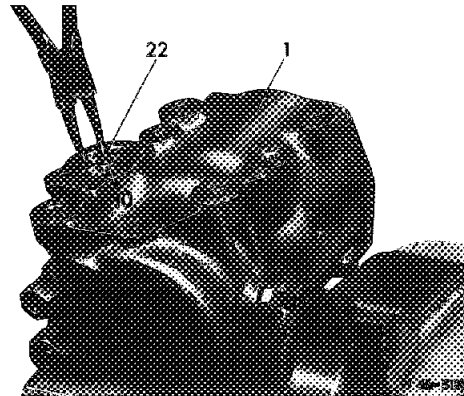

### Steering case, working piston

---

79 Carefully install working piston (5) complete with steering worm (3), steering nut (4) and bearing cap (7) into steering case, while introducing straightedge of steering nut into groove of control valve.

#### **Caution!**

Do not use force.

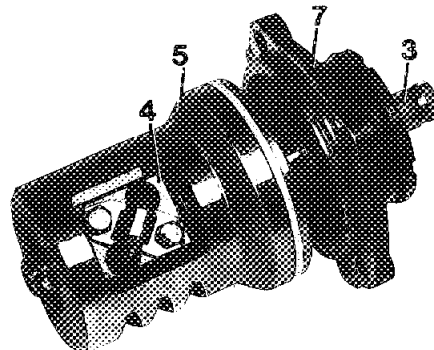

146-11835

80 Turn bearing cap in such a manner that the oil duct on steering case is in alignment with oil bore on bearing cap. Pay attention to correct seat of O-rings. Then screw in hex. screws without spring rings and washers and tighten to 70 to 75 Nm.

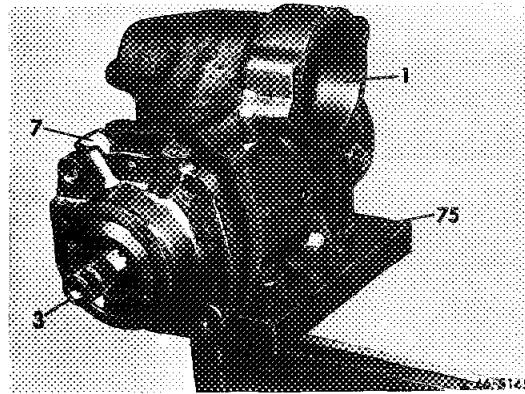

81 Turn steering worm in such a manner that the center tooth gap on working piston is in center of steering case.

**Pitman shaft, casing cover**

82 Insert O-rings (54, 55 and 63) into casing cover (8).

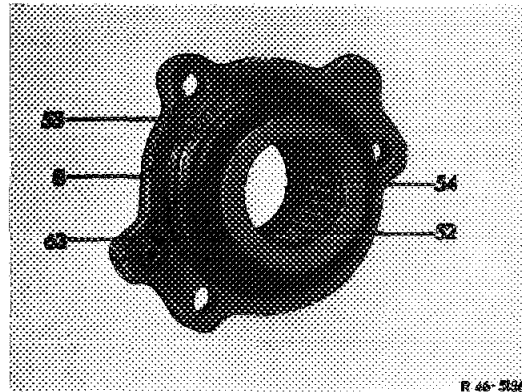

83 Insert adjusting screw (47) including thrust washer (48) and locking ring (49) into pitman shaft (2), while paying attention to perfect seat of locking ring.

**Note:** The adjusting screw should be mounted in pitman shaft as much as possible free of play. For this purpose, thrust washers of the following thickness are available: 2.65 – 2.70 – 2.75 – 2.80 – 2.85 – 2.90 – 2.95 – 3.00 – 3.05 – 3.10 mm.

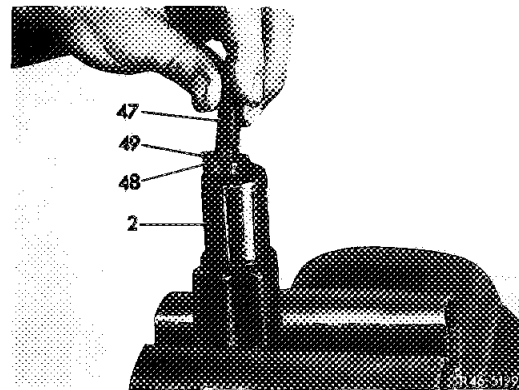

84 Place thrust ring (50) on adjusting screw (47) and insert locking ring (51).

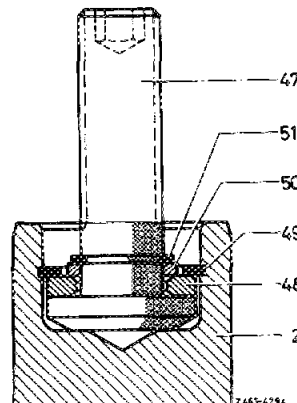

## 46-220 Reconditioning steering gear

---

85 Press radial sealing ring (56) into casing cover (8) and insert locking ring.

Special tool 116 589 07 43 00

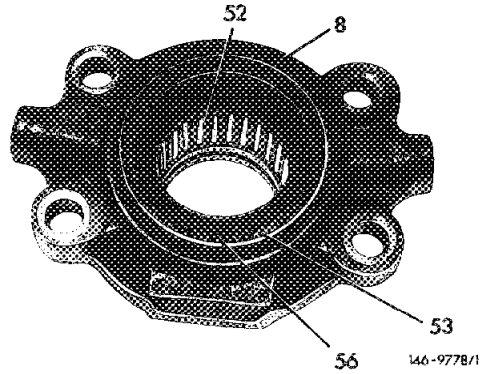

86 Place casing cover (8) on pitman shaft (2), then insert pitman shaft into steering case. Make sure that the center tooth of pitman shaft enters center tooth gap of working piston and that the O-rings are correctly seated.

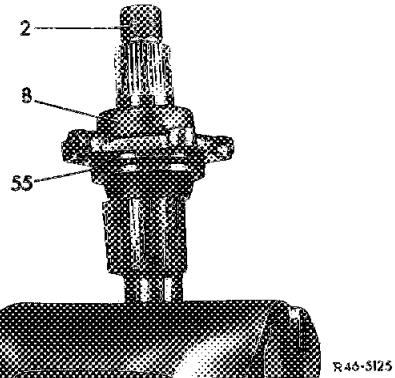

87 Screw adjusting screw (47) into steering case until it is hard to move.

88 Turn casing cover (8) in such a manner that both oil ducts are one above the other. Then screw in new plastic-coated hex. screws and tighten to 30–35 Nm.

89 Loosen adjusting screw (47) until steering worm can be easily rotated, then measure friction torque of steering worm and take note of value.

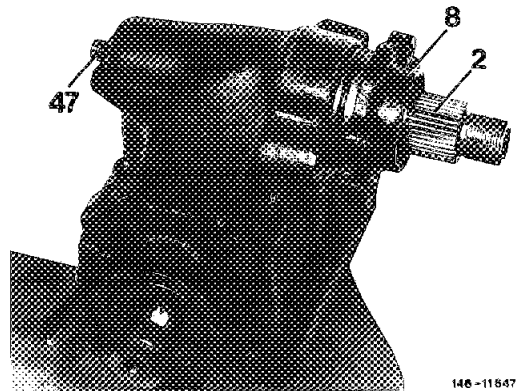

90 Slip measuring device (70) on steering worm (3). Adjust pressure device of pitman shaft (2), for this purpose turn adjusting screw to the left until friction torque has increased by 40 – 60 Ncm. That is, when the steering worm is turned beyond center position the friction torque should amount to 110 – 160 Ncm. The steering is correctly set, if a weight of 2000 g in notch "6" to "8" of measuring device turns steering worm beyond center position.

Special tool 116 589 03 21 00

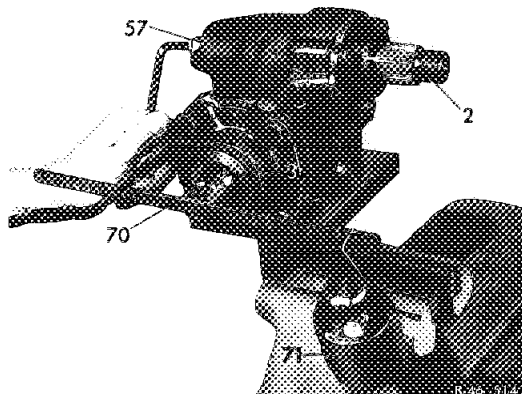

**Attention!**

When turning beyond center position, a light pressure point should be noticeable. When the steering worm is turned from lock to lock, the steering should not bind.

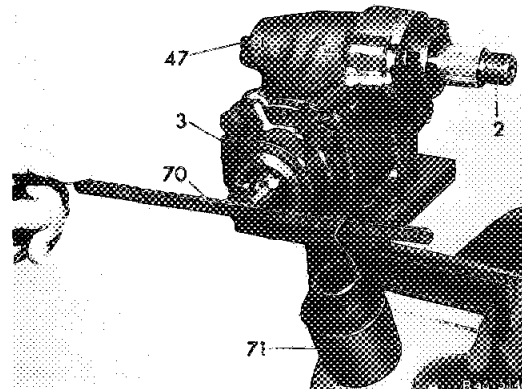

91 The friction torque can also be measured with torque wrench in combination with respective socket.

Special tool: 123 589 02 21 00,  
123 589 00 08 00

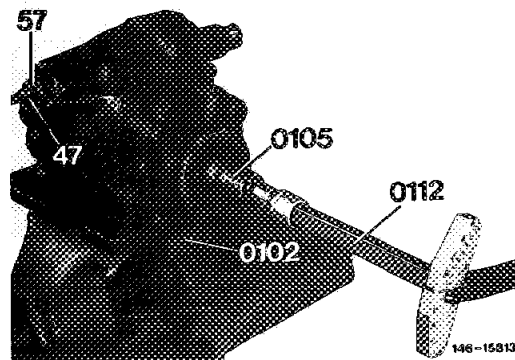

92 Screw SEAL-LOCK collar nut on adjusting screw (47) and tighten to 60-65 Nm, while applying counterhold to adjusting screw.

93 Check total friction torque once again (refer to item 43 to 47) which should amount to 110-160 Ncm = 2000 g in notch "6" to "8" of measuring device.

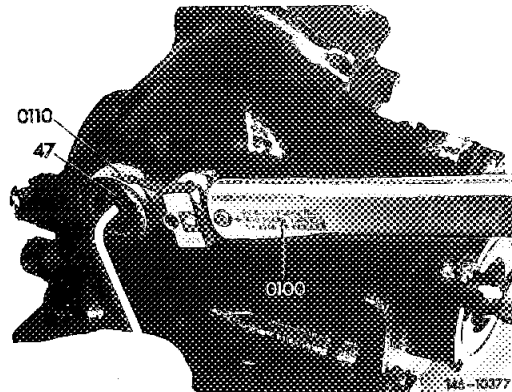

94 On steering with automatic compensation for play, slightly turn steering worm until working piston is no longer in center of steering.

95 Insert bushing (95) and spring bolt (94) into steering case.

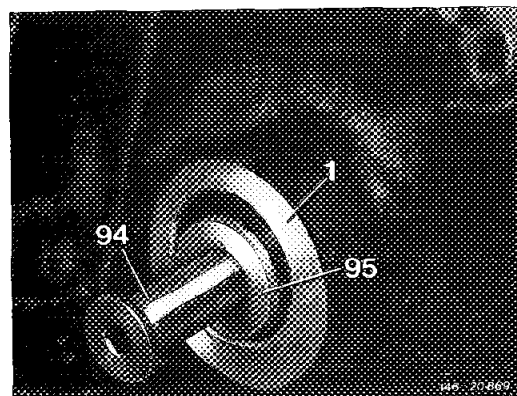

## 46-220 Reconditioning steering gear

---

96 Renew O-ring (96) on cover (92).

97 Insert compression spring (93) into cover and cover into steering case.

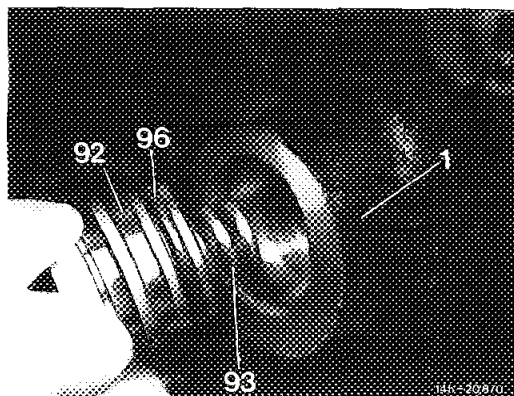

98 Insert locking ring (99) into steering case. Place thrust ring (98) on cover (92).

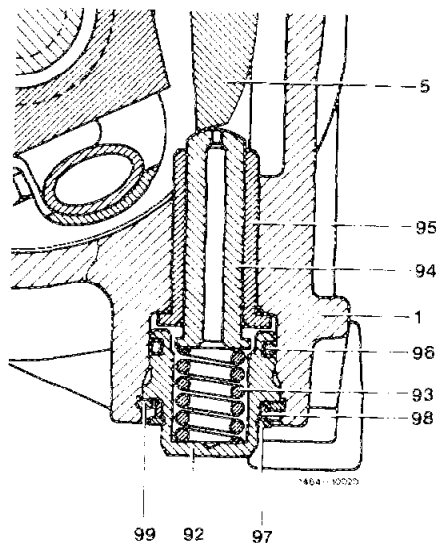

99 Insert locking ring (97) into cover. Make sure that locking rings are correctly seated.

